

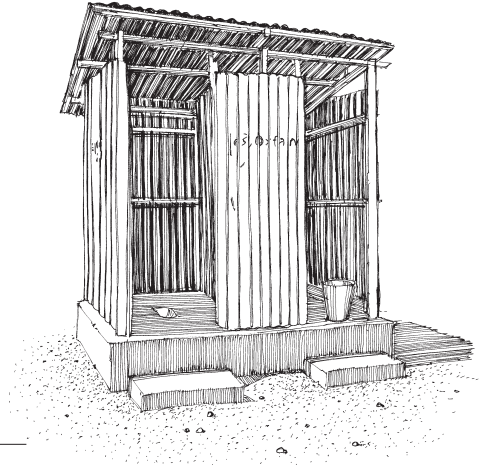

Technical options for excreta disposal in emergencies

Sanitation is the efficient disposal of excreta, urine, refuse, and sillage. Initially, indiscriminate defecation is usually the main health hazard in refugee camps. This technical note outlines ways in which excreta and urine can be managed during the early stages of an emergency, while long-term solutions are devised. (See Technical Note 7 for guidance on managing solid waste.) The technical options for emergency excreta disposal are limited and simple. If they are to work, however, they must be properly managed and be understood and supported by the community.



Immediate measures

The immediate tasks after a disaster are as follows:

- **Obtain the services of a good translator.** Effective sanitation provision has more to do with views and opinions of the user population than the technology. It is very important to have a good relationship with users, and that requires the skills of a competent translator.
- **Consult with all interested parties** including representatives of the affected population, aid agencies and government officials.
- **Survey the site** to gather information on existing sanitation facilities (if any), the site layout, population clusters, topography, ground conditions, and available construction materials.
- **Prevent indiscriminate defecation.** Especially prevent defecation in areas likely to contaminate the food chain or water supplies.
- **Select areas where defecation may safely be allowed.**

Managing open defecation

People affected by a disaster still need to defecate! They will attempt to follow traditional practices, but if that is not possible they will defecate wherever they can. Your first task is to prevent excreta contaminating water supplies or the food chain, so you must prevent defecation in areas such as:

- **the banks of rivers, streams, or ponds** which may be used as a water source (and if water is to be abstracted from shallow wells, then it is important to ensure that these wells are situated upstream of the defecation areas); or
- **agricultural land** planted with crops, particularly if the crops are soon to be handled or harvested for human consumption.



Figure 14.1. Prevent open defecation in areas planted with crops

Keeping people away from specific areas is not easy, particularly where traditional habits make such practices common. It may be necessary to construct a physical barrier, such as a fence, or to set up patrols to keep people away. This approach can only be very temporary. Move as quickly as possible to provide appropriate excreta disposal facilities and encourage people to use them.

Defecation fields

These should be located so that they are easily reached by the community but do not pollute water supplies or sources of food. It is better to provide a number of small fields equally spread around the affected population as this will reduce the walking distance for most users. It will also allow for flexibility of operation and the separation of men and boys from women and girls.

The defecation field should be screened and divided into small strips so that a different strip can be used each day. The area of the field farthest from the community should be used first, so that people do not have to walk across contaminated

ground to reach the designated area (Figure 14.2). They can be improved by digging shallow trenches along the centre of each strip and piling the excavated soil to one side. Users are encouraged to defecate in the trench and then cover their waste with the soil piled beside it.

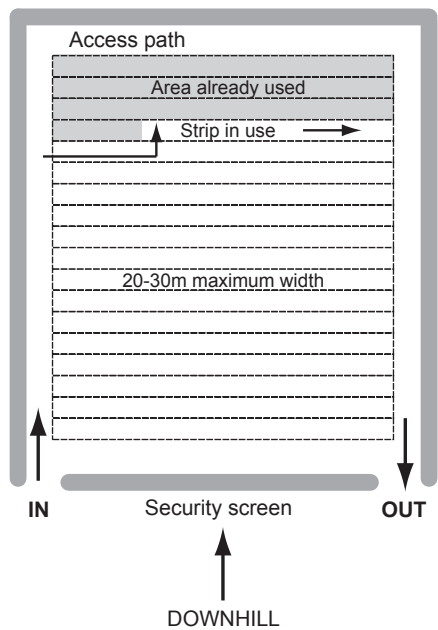

Figure 14.2. Plan of a defecation field

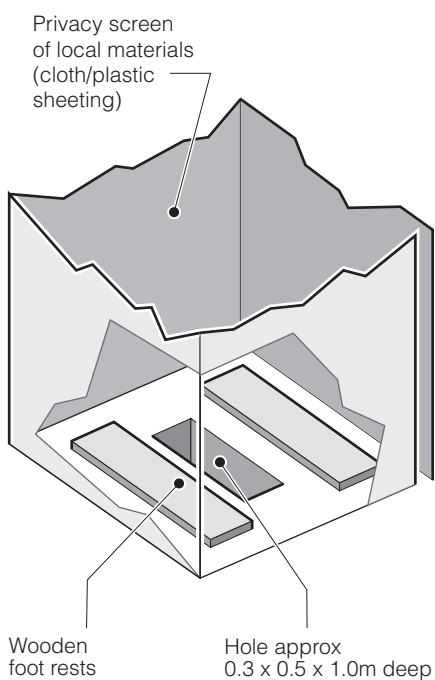

Figure 14.3. A shallow family latrine

Defecation fields have a short life and are difficult to manage. They should be replaced with more sustainable solutions as soon as possible.

Shallow family latrines

Providing each family with its own latrine has many advantages and must always be the ultimate goal of any sanitation programme. In the first few days of an emergency, this can be a simple structure such as shown in Figure 14.3. A key advantage is that providing the affected community with tools to build and maintain the latrines is practically the only input required.

If family latrines are not possible (for example, because of the lack of space) then some form of communal latrines will have to be provided.

Shallow trench latrines

Trenches around 0.2m to 0.3m wide, 1.5m deep and 4.0m long are surrounded by a temporary screen (Figure 14.4). Users defecate by squatting across the trench. After use, users cover their faeces with some of the soil dug out of the trench using the spade provided. If the ground is wet or soft, a piece of wood can be laid along each side of

the trench. Some trenches should be dug narrower so that they can be used by small children and the elderly.

Shallow trench latrines can quickly become smelly, especially in hot and humid climates. All faeces must be covered at least once a day and trenches closed when the contents reach 0.3m from the ground surface.

Deep trench latrines

A trench 0.8m to 0.9m wide, 6.0m long and at least 2.0m deep is covered by a wooden or plastic floor and divided into six cubicles (Figure 14.5). The top 0.5m of the trench walls should be lined with plastic sheeting for ease of cleaning and to prevent the sides from collapsing. The cubicles and privacy screen can be made of plastic sheeting on a light wooden frame. A roof can be provided if necessary. A drainage ditch should be dug around the latrine to divert surface water.

Each day the contents of the trench are covered by a layer of soil approximately 0.1m deep. This will reduce the smell and prevent flies from breeding in the trench.

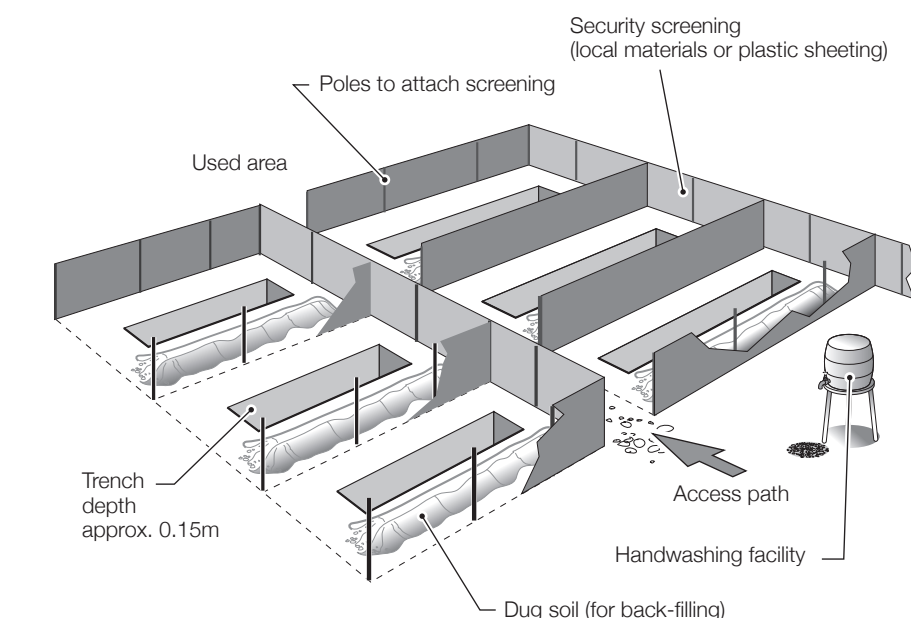
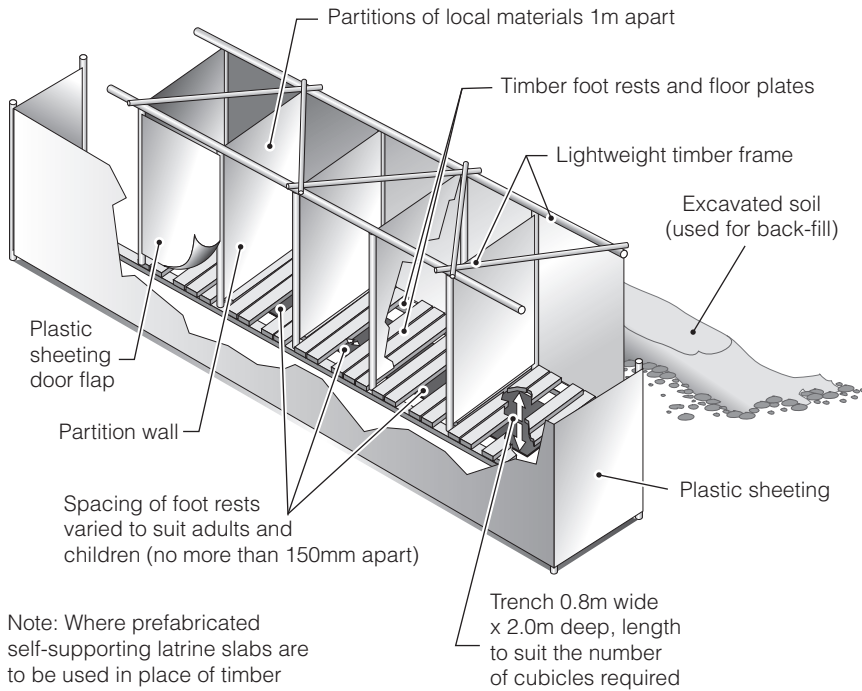

Figure 14.4. Trench defecation fields



Note: Where prefabricated self-supporting latrine slabs are to be used in place of timber cubicle sizes may need to be adjusted to fit slab width (e.g. 0.8m)

Figure 14.5. Deep trench latrines

When the bottom of the trench has risen to within 0.3m of the surface, the trench is filled with soil and the latrine is closed.

A trench latrine system is very labour-intensive and requires constant supervision. Not only must the contents of each latrine be covered each day, but new latrines must be prepared, old ones filled in, and regularly-used latrines must be cleaned. Close supervision is essential. A poorly-maintained latrine will quickly become offensive to the community and will not be used.

Making use of existing facilities

In urban areas, it may be possible to make use of existing facilities such as sewers, public toilets, bucket latrines, or stormwater drains. Temporary latrines, such as the one shown in Figure 14.6, can be constructed over a sewer or drain. Additional water may be required to carry the wastes through the system.

Mobile latrine blocks

In Europe and North America, mobile latrine blocks are common. Typically, these contain a number of toilet cubicles, sometimes provided with urinals and handwashing facilities. A tank is provided for clean water and another to collect waste. The waste tank is emptied using a portable vacuum tanker.

The deployment of mobile latrine blocks is not limited to industrialized countries. Provision for the ultimate disposal of the waste must, however, be part of their deployment.

Borehole latrines

In areas with deep soil, many borehole latrines can be built in a short time using hand augers. The holes are usually 0.3m to 0.5m in diameter and 2.0m to 5.0m deep (Figure 14.7). The top of each hole is lined with a pipe, and two pieces of wood are provided for footrests. Borehole latrines should be closed when the contents are 0.5m from the surface.

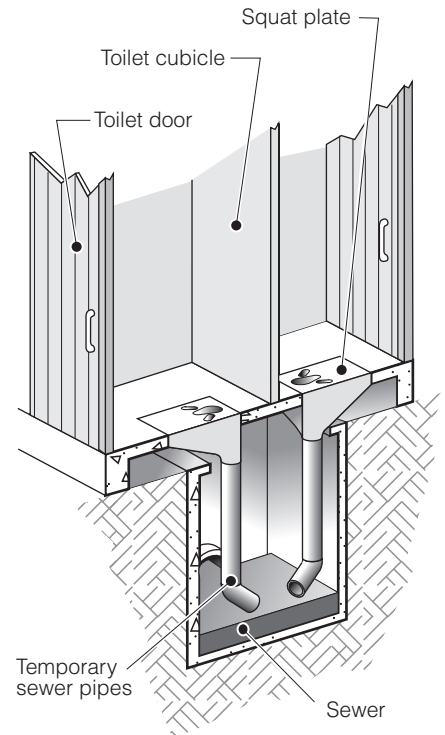
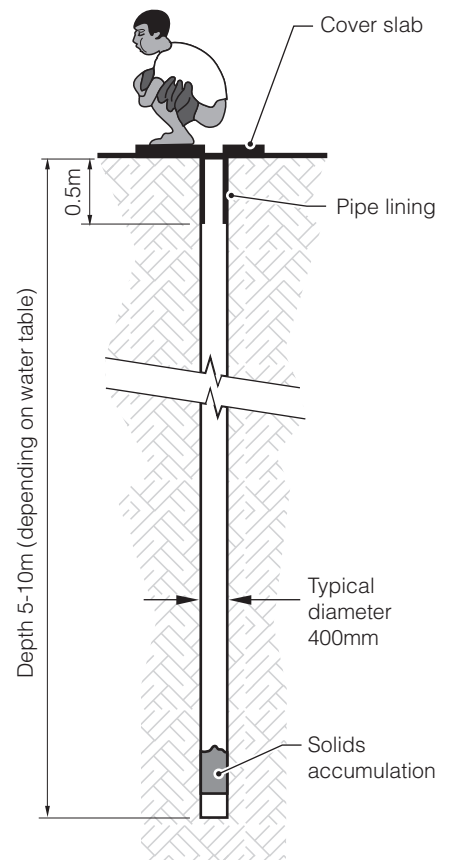

Figure 14.6. Temporary toilet over a sewer



Note: Some soil conditions may require a pipe lining greater than 0.5m

Figure 14.7. A borehole latrine

Packet and plastic bags

If the affected population is on the move, or if it is not possible to construct any form of latrine (such as in a flooded area), a simple plastic bag may be the only disposal option. The bags should be strong, water-tight and have a sealable top. Users should defecate directly into the bag and then seal it. The bags need to be collected regularly and taken away for burial. Biodegradable bags are preferred for their limited impact on the environment.

Chemical toilets

Portable chemical toilets have been used in emergencies in South and Central America. Typically, they are light-weight portable cubicles fitted with toilet seats with sealed holding tanks below. To reduce the smell, the tank is partially-filled with chemicals before use. The holding tank must be emptied regularly.

Overhung latrines

Overhung latrines are an option in flood situations as long as water is flowing. A simple wooden structure, either built over the water (Figure 14.8) or floating on the water, allows users to defecate directly into the flowing water. This is rarely a major health problem as the volumes of water involved are large. Besides, the water is likely to be polluted already!

Further information

Harvey, P., Baghri, S. and Reed (2002) *Emergency Sanitation: Assessment and programme design*, WEDC, Loughborough University, UK.

Harvey, P. (2007) *Excreta disposal in emergencies – a field manual*. WEDC, Loughborough University, UK <http://wedc.lboro.ac.uk/publications/>



World Health Organization

Water, Sanitation,
Hygiene and Health Unit
Avenue Appia 20
1211 Geneva 27
Switzerland

Telephone: + 41 22 791 2111
Telephone (direct): + 41 22 791 3555/3590
Fax (direct): + 41 22 791 4159
Email Coordinator: bosr@who.int
URL: www.who.int/water_sanitation_health

Prepared for WHO by WEDC. Author and Series Editor: Bob Reed.

Editorial contributions, design and illustrations by Rod Shaw

Line illustrations courtesy of WEDC / IFRC. Additional graphics by Ken Chatterton.

Water, Engineering and Development Centre Loughborough University Leicestershire LE11 3TU UK
T: +44 1509 222885 F: +44 1509 211079 E: wedc@lboro.ac.uk W: <http://wedc.lboro.ac.uk>

WEDC

Raised latrines

If the ground is rocky or the water table is high, many of the options described will be unsuitable because they depend on deep pits. An alternative is to raise the pit above ground level (Figure 14.9).

The walls of the pit can be extended above ground level using local materials such as wood, bamboo or stone. The lining is then surrounded by a bank of soil to prevent it collapsing and to support the toilet cubicle. In practice, it is normally only possible to raise latrines about 1 to 1.5m above ground level. Higher latrines are rarely acceptable to users.

Figure 14.8. An overhanging latrine

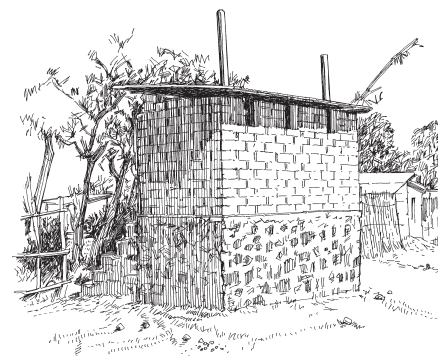
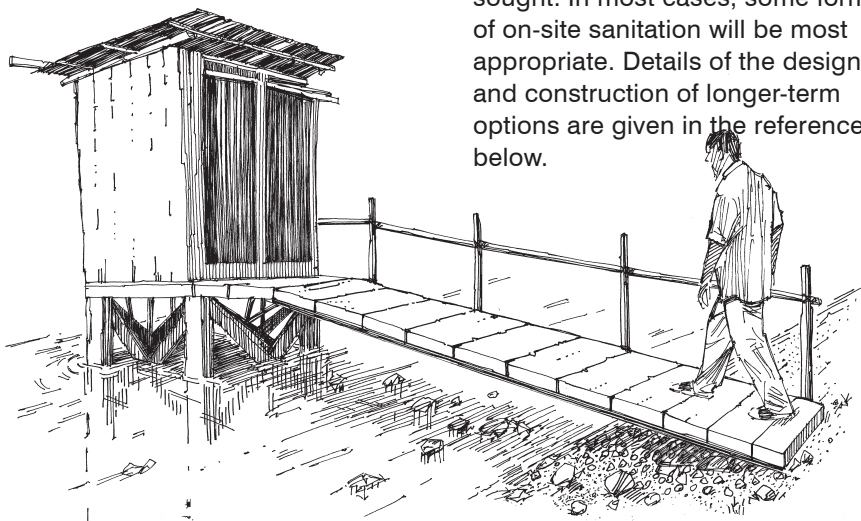

Figure 14.9. A raised latrine

Long-term solutions

Most of the options in this note are only temporary. As soon as it becomes obvious that the community is likely to remain in their new location for any length of time then longer-term solutions should be sought. In most cases, some form of on-site sanitation will be most appropriate. Details of the design and construction of longer-term options are given in the references below.