

# **Emergency Excreta Disposal Standards and Options for Haiti**

**Final Draft**

April 2010





Document written by Bob Reed

WEDC (Water, Engineering and Development Centre)  
Loughborough University, Leicestershire LE11 3TU, UK  
<http://wedc.lboro.ac.uk/>

Financial support provided by:

The Crown Agents for Overseas Governments and Administrations Limited.  
St Nicholas House, Surrey SM1 1EL, UK

© DINEPA & Global WASH Cluster 2010

Any part of this publication, including the illustrations (except items taken from other publications where the authors do not hold copyright) may be copied, reproduced or adapted to meet local needs, without permission from the author/s or publisher, provided the parts reproduced are distributed free, or at cost and not for commercial ends, and the source is fully acknowledged.

## Acknowledgments

The author acknowledges to support of the following organisations in the production of this document.

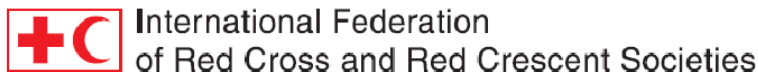

## EMERGENCY EXCRETA DISPOSAL STANDARDS AND OPTIONS FOR HAITI

---

Special thanks are extended to the following individuals for supporting the author's visit to Haiti, providing photographs, additional information and reviewing the document

Alban Mille (French Red Cross)	Mille Alban (French Red Cross)
Anthony Kilbride (MSF Spain)	Nial Boot (GOAL)
Ben; Harvey (WASH Cluster)	Nicholas Brooks (Oxfam GB)
Frederico Sittaro (MSF Belgium)	Nicole Klaesener (ACTED)
Gian Luca Salone (IFRC)	Otto Nodeland (NCA)
Ingrid Henrys (DINEPA)	Pauline Mwaniki (WASH Cluster)
Jean Mark Luishomme (Fondation le Berger)	Richard Higgins (New Directions Foundation)
Jean Paul Barlatier (ACF)	Rodrigo Silva (Permaculture Volunteer)
Julien Eyrard (ACF)	Theo Huitema (World Vision)
Kristjon Thorkelssonk (IFRC)	Therese Dooley (UNICEF)
Luca Salone (IFRC)	Trish Morrow (Mercy Corps)
Marco Lombardini (COOPI)	Vincent Dupin (NCA)

## Table of Contents

<b>Acknowledgments</b>	<b>3</b>
<b>Table of Contents</b>	<b>5</b>
<b>1. Introduction</b>	<b>9</b>
1.1 Background	9
1.2 Document development process	9
1.3 Special challenges for sanitation in Haiti	9
1.4 Sanitation scenarios	10
1.5 Purpose of this document	10
1.6 Scope	10
1.7 Document format	11
<b>2. Standards</b>	<b>12</b>
2.1 Toilets	12
2.2 Storage, treatment and disposal of excreta	14
2.3 Hand washing facilities	15
<b>3. Selection tools</b>	<b>16</b>
3.1 Summary of excreta disposal technologies	16
3.2 Short list selection tool	16
<b>4. Toilets<sup>(2)</sup></b>	<b>19</b>
4.1 Getting there	19
4.2 Block location and layout	20
4.3 Getting in	21
4.4 The toilet cubicle	22
<b>5. Options for the storage of excreta</b>	<b>27</b>

5.1	Trenches	27
5.2	Pits	28
5.3	Single use biodegradable bags	29
5.4	Holding tanks	30
5.5	Urine diversion	31
5.6	Communal septic tanks	32
5.7	Communal aqua privies	33
5.8	Biogas	34
<b>6.</b>	<b>Tank emptying</b>	<b>35</b>
6.1	Mechanical pumps	35
6.2	Hand operated pumps	36
6.3	Manual emptying	37
6.4	Reducing sludge volume	37
<b>7.</b>	<b>Sludge transport</b>	<b>38</b>
7.1	Vacuum tankers	38
7.2	General garbage trucks & other vehicles	38
<b>8.</b>	<b>Treatment and disposal of excreta</b>	<b>39</b>
8.1	Burial	39
8.2	Garbage site disposal	39
8.3	Sludge drying beds	40
8.4	Co-composting	40
8.5	Waste stabilisation pond	41
8.6	Constructed wetlands	42
<b>9.</b>	<b>Hand washing facilities</b>	<b>43</b>
9.1	Designs	43

9.2	Waste water disposal	44
<b>10.</b>	<b>Exit strategies</b>	<b>45</b>
10.1	Close the toilet	45
10.2	Hand over to the community	45
10.3	Hand over to a private contractor	45
10.4	Hand over to another NGO	46
10.5	Give them to the Government	46
10.6	Hand community toilets to the users	46
<b>11.</b>	<b>References</b>	<b>47</b>
<b>12.</b>	<b>Technical drawings</b>	<b>48</b>
12.1	IFRC Four cubicle over 500 gallon storage tank	48
12.2	UNICEF three compartment trench toilet	50
12.3	Oxfam emergency latrine	52
12.4	ARI Temporary school latrine block	56
12.5	Construction details for a GOAL trench toilet	60
12.6	Aprosifa two compartment pit toilet	61
12.7	Timber support systems for trenches in unstable ground	63
12.8	Pit lined with sand bags	63
12.9	Reinforced concrete toilet squatting slab	64
12.10	Unreinforced domed squatting slab	64
12.11	Timber frame for trench toilet	65
12.12	Toilet cubicl frame made of uPVC pipe	66
12.13	Layout of a women's toilet and washroom area	67
12.14	Designs for hand washing areas	68
12.15	Design and BoQ for trench latrine	76





# 1. Introduction

## 1.1 Background

A magnitude 7.0 earthquake, the strongest ever recorded in Haiti, struck at 4:53 local time on Tuesday January 12<sup>th</sup> causing widespread destruction. A further earthquake reported at over 6.1 occurred on the morning of the 20<sup>th</sup> January. The capital Port-au-Prince was heavily affected and reports from outlying towns suggests the damage is considerable elsewhere. Tentative data suggests that the disaster has led to the establishment of over 900 informal settlements, mainly in the Port au Prince area, housing a population of around 1.5 million. Already weak water and sanitation systems have been badly damaged, leaving populations of entire districts deprived of basic services. By April 2010, despite the efforts of the Government of Haiti, the UN and international and national NGO's, many temporary camps were still without adequate sanitation facilities. With the imminent onset of the rainy season, there was grave concern that the lack of adequate facilities would lead to a major outbreak of excreta related disease.

In an attempt to improve the quality of the service provided, standardize technologies and practices, and support new organisations entering the sector; the Excreta Design Technical Working Group of the WASH Cluster asked the author to prepare this document.

## 1.2 Document development process

This document was developed during the author's visit to Haiti between the 5<sup>th</sup> and 26<sup>th</sup> April 2010.

After a preliminary briefing from the WASH Cluster Sanitation Adviser the author visited a number of temporary settlements around Port au Prince to investigate the range of technologies being used for excreta disposal. At the same time he discussed the issues and challenges being faced by agencies while they tried to improve sanitation provision.

Based on the information gathered, the author prepared a draft statement of elements<sup>1</sup> and indicators appropriate to the Haiti situation. These were based on the SPHERE Humanitarian Charter but expanded and adapted to meet local needs. A working party, comprising representatives of the WASH Cluster Sanitation Working Group (SAG), reviewed the draft standards and indicators at a workshop on the 15<sup>th</sup> April.

The author then revised the standards and guidelines and added details of the technology options likely to be appropriate for the circumstances found in Haiti. These included a catalogue of the technologies observed during the visit and other solutions that had been used in similar situations in other countries. A further workshop with the SAG on the 22<sup>nd</sup> April reviewed the full draft document.

When the author left Haiti, the document was in a final draft form and awaiting formal approval by the Government of Haiti.

## 1.3 Special challenges for sanitation in Haiti

The situation in Haiti, particularly Port au Prince makes the provision of sanitation services very challenging. This makes the attainment of SPHERE standard indicators at this time extremely difficult. The specific challenges which are preventing agencies meeting standards include:-

- Landownership – many camps are on private land and often permission to provide services is forbidden, limited and at best takes much negotiation –including being asked for payment in order to provide services. Some sites are being threatened with eviction

---

<sup>1</sup> It was decided not to call the tools for measuring whether the standards had been met 'indicators'. The SAG wanted to use a term that indicated that the measurement statements minimum values, not ones to be aspired to. They therefore decided to use the term 'element' instead.

- Space – it has been calculated in many sites that in order to be able to meet standards of what might normally be achieved, there would be little room for tents! In planned relocation sites there is certainly the possibility to more meet international standards
- No camp management – no overall site coordination/planning and coherent/consistent link with the community – multiple agencies working in the same camp (whilst no-one in other camps) making implementation complicated as agencies bring different approaches which often cause problems with the camp community – resulting in the destruction of some facilities in some sites
- Customs is becoming more difficult with many organizations materials being stuck for several weeks.
- Ground conditions – many sites are steeply sloping, have rock close to the surface; are covered with concrete or tarmac, or are subject to frequent flooding
- Environmental issues – the disposal of garbage and toilet wastes is severely restricted, especially in Port au Prince. There is only one garbage site for the whole city and its operation and management has been badly affected by the earthquake.

### **1.4 Sanitation scenarios**

Despite the earthquake happening over three months ago, organisations are still struggling to provide even the most basic sanitation services. The author was specifically requested to address current issues and not to focus on longer term solutions. To meet current needs in Haiti this document addresses four scenarios:

- The provision of immediate sanitation needs;
- Medium term solutions for sanitation;
- Options for high density urban temporary camps; and
- Options for rural communities affected by the earthquake.

A small number of technologies reviewed during the visit were unsuitable for immediate or medium term responses but could be options for longer term responses. They have been included in the document for completeness.

### **1.5 Purpose of this document**

As part of the post earthquake response; present immediate and medium term design options and standards for the collection and disposal of excreta specifically tailored for the Haiti context.

### **1.6 Scope**

This document provides an overview of the most important options and standards. As such it cannot provide the detailed information that some readers may require. To overcome this, sources of more detailed information are provided in the text.

The document concentrates on the issues of toilet design, excreta storage and treatment as these are the most challenging problems. However a section on hand washing is also included as it is an important element in toilet design and user hygiene.

## 1.7 Document format

The document is broadly divided into the following sections:

- **Standards and elements** – Describe the minimum standard of service that sanitation providers should provide
- **Sanitation selection** – Basic tools to assist users decide on the most appropriate technology choices for a particular situation.
- **Toilets** – Describes, with the aid of photographs and diagrams, the key elements in toilet design and construction to meet the needs of users
- **Excreta disposal technology** – Describes the range of technologies suitable for the storage, transport, treatment and disposal of human wastes in Haiti.
- **Hand washing facilities** – Illustrates approaches to the provision of hand washing facilities and the disposal of their waste water.
- **Exit strategies** – Describes the main approaches taken by organizations in previous emergencies to exiting the area whilst ensuring that the services they provided continue to function.
- **Toilet designs** – A collection of design drawings for toilets taken from partner organizations and international literature.

## 2. Standards

Clear and simple standards adapted to suit the special circumstances in Haiti are essential for ensuring all implementing organisations work towards a common goal. To a large extent the standards are based on the fundamentals set out in the SPHERE Humanitarian Charter (2004). However they have been edited and expanded to reflect the current situation in Haiti. The standards describe, in general terms, what emergency interventions are trying to achieve, i.e. the objectives of our interventions. However, they do not describe how we know when we have achieved them. A working group within the Haiti WASH cluster met to discuss the issue of indicators and the rest of this chapter is a reflection of their decisions. The group decided to divide the indicators into two groups;

- **Essential elements** – Levels of service that should be met immediately. They are the minimum levels necessary to ensure populations are protected from the major risks of poor excreta disposal practices.
- **Ideal elements** – Additional levels of service necessary to fully meet the standard statements.

### 2.1 Toilets<sup>2</sup>

Sphere has two standards governing toilets, these are:

**Access to & number of cubicles:** *People have adequate numbers of toilets, sufficiently close to their dwellings, to allow them rapid, safe and acceptable access at all times of the day and night.*

**Design, construction and use of toilets:** *Toilets are sited, designed, constructed and maintained in such a way as to be comfortable, hygienic and safe to use.*

Table 1 sets out the essential and ideal elements that should be met to achieve these standards

---

<sup>2</sup> In this document the toilet refers to the building in which people defecate. To a large extent, its design, location, and construction are independent of the way that excreta is stored, treated and disposed.

## EMERGENCY EXCRETA DISPOSAL STANDARDS AND OPTIONS FOR HAITI

Table 1. Essential & ideal elements for toilets	
Essential elements	Ideal elements
<p>The maximum number of users per cubicle<sup>3</sup> in temporary settlements is 100.</p> <p>The maximum number of families using a toilet cubicle in resettlement sites is 20</p> <p>The minimum number of public toilets in any camp is 2, one for men and one for women.</p> <p>Toilets in temporary settlements are no more than 300m from their users and accessible in safety by all.</p> <p>Toilets on resettlement sites are no more than 300m from the designated families that use them and are accessible in safety by all the users.</p> <p>Toilets are segregated according to sex or assigned to designated families.</p> <p>Users (especially women) have been consulted on the siting and design of the toilet.</p> <p>Public toilets<sup>4</sup> are designed, built and located such that:</p> <ul style="list-style-type: none"> <li>• At least one cubicle in 20 can be used by vulnerable sections of the population, including, older people, pregnant women physically and mentally disabled people and those infected with HIV/AIDS.</li> <li>• Provision is made for the hygienic collection and disposal of Children's faeces.</li> <li>• they allow for the disposal of women's sanitary protection</li> <li>• they minimise fly and mosquito breeding</li> </ul> <p>All toilets are designed, constructed and located such that</p> <ul style="list-style-type: none"> <li>• They minimise the threats to users, especially women and girls, day and night</li> <li>• They provide privacy in line with the norms of the users, a cubicle with a lockable door;</li> </ul> <p>Toilets are cleaned and maintained in such a way that they do not deter use.</p> <p>Workers operating and maintaining toilets are equipped with appropriate protective clothing and cleaning materials.</p> <p>Appropriate anal cleaning materials are provided where users cannot reasonably be expected to provide their own.</p> <p>Where excreta storage systems are expected to be emptied, provision is made for the separate collection and disposal of used anal cleaning material that may damage the collection and disposal systems.</p> <p>Ownership of facilities and its consequent responsibilities are clearly defined and understood by all parties.</p> <p>A clear strategy exists for the continued operation and maintenance of the toilet after the implementing agency ceases to be responsible.</p>	<p><i>The following are in addition to the Essential Elements except where the numbers given replace those previously quoted.</i></p> <p>The maximum number of users per cubicle in temporary settlements is 20.</p> <p>The maximum number of families using a toilet cubicle in resettlement sites is 4</p> <p>Toilets in temporary settlements are no more than 50m from their users and accessible in safety by all.</p> <p>Toilets on resettlement sites are no more than 50m from the designated families that use them and are accessible in safety by all the users.</p> <p>Public toilets are designed, built and located such that:</p> <ul style="list-style-type: none"> <li>• At least one cubicle in 5 can be used by vulnerable sections of the population, including, older people, pregnant women physically and mentally disabled people and those infected with HIV/AIDS.</li> <li>• Provision is made for the hygienic collection and disposal of Children's faeces. At least one cubicle in 10 is appropriate for the use of small children</li> </ul> <p>All toilets are designed, constructed and located such that the choice of pedestal or squatting toilet is made in the light of the users' previous customs and practices.</p>

<sup>3</sup> The cubicle is the room in which people defecate.

<sup>4</sup> Public toilets are used by anyone at any time. Communal toilets are used by designated groups of families.

## 2.2 Storage, treatment and disposal of excreta

For the purposes of this emergency the following standard will be used:

*Excreta will be stored, transported, treated and disposed of in a way that does not expose people to harmful pathogens, minimizes offensive odours in populated areas and minimizes the impact on the environment.*

Table 2 sets out the essential and ideal elements that should be met to achieve these standards

Table 2. Essential and ideal elements for excreta storage, transportation, treatment and disposal	
Essential elements	Ideal elements
<p>Subject to local regulations, excreta storage, treatment and disposal systems should not pollute clean surface water sources, be at least 30 metres from any groundwater source and the bottom of any pit be at least 1.5 metres above the maximum height of the water table. This does not apply to saline groundwater (<math>&gt;1,500\mu\text{S}/\text{cm}^2</math>).</p> <p>Storage systems such as pits, tanks, etc. are suitably designed to prevent collapse</p> <p>Storage systems such as pits, tanks, buckets, etc intended to be regularly emptied are designed and located to accommodate the appropriate emptying device,</p> <p>Excreta are transported in an enclosed leak proof vehicle that is only emptied in an authorized place.</p> <p>Treatment and/or final disposal sites prevent the exposure of the general population to public health risks.</p> <p>Any environmental contamination is minimized</p> <p>Transfer operations should not result in the spillage of excreta</p> <p>Workers involved in the emptying, transport, treatment or disposal of excreta are provided with protective clothing and advice on how to protect their health and safety.</p>	<p><i>The following are in addition to the Essential Elements except where the numbers given replace those previously quoted.</i></p> <p>Storage systems such as pits, tanks, buckets, etc. are sized to maximise the efficiency of the emptying vehicle.</p>

## 2.3 Hand washing facilities

For the purposes of this emergency the standard will be:

*Hand washing facilities containing clean water and soap are conveniently located near toilets and their use is actively promoted.*

Table 3 sets out the essential and ideal elements that should be met to achieve these standards.

<b>Essential elements</b>	<b>Ideal elements</b>
<p>One hand washing dispenser is provided for every 10 cubicles.</p> <p>Every camp has at least one hand washing facility.</p> <p>Hand washing reservoirs are covered to prevent contamination and fitted with a dispensing device<sup>5</sup>.</p> <p>The dispensing device is located in easy reach of all users, especially children, of the toilets (in terms of position and height)</p> <p>The reservoir is replenished with clean water before it becomes empty</p> <p>Each dispensing device is accompanied by soap</p> <p>Facilities are provided for the safe disposal of waste water</p> <p>Measures are regularly taken to actively encourage toilet users to wash their hands at the end of their visit.</p>	<p><i>The following are in addition to the Essential Elements except where the numbers given replace those previously quoted.</i></p> <p>One hand washing dispenser is provided for every 5 cubicles.</p>

<sup>5</sup> A dispensing device is the point where the water leaves the hand washing facility. It could be a tap or a piece of hose pipe. Whatever it is, it should be easy to use, prevent contamination of the rest of the water in the reservoir and not waste water.

### 3. Selection tools

#### 3.1 Summary of excreta disposal technologies

Table 4 summarizes the most suitable situations in which the technologies described in this document are likely to be most suited. There are many different factors affecting the choice of technology so this table must only be seen as a guide. Once you have selected likely technology choices, read the relevant sections in the document (follow the cross reference given) before making the final choice.

Technology	Immediate response		Medium term		Longer term <sup>6</sup>	
	Urban	Rural	Urban	Rural	Urban	Rural
Bio degradable plastic bags (section 5.3)	+++					
Trench storage (section 5.1)	+++	+++				
Simple and ventilated pits (section 5.2)		+++	++	+++	+	+++
Arborloos (section 5.2)		+++		+++		+++
Raised simple and ventilated pits (section 5.2)		+++	++		++	+++
Sealed holding tanks (section 5.4)	+++		+++			
Septic Tanks (section 5.6)			+++	+++	+++	+++
Aqua privies (section 5.7)			+++		+++	
Urine diversion (section 5.5)	+	++	+	++	++	+++
Biogas (Section 5.8)					+++	+++

#### Key

- +++ Technology very suitable for the situation
- ++ Technology may be suitable for situation
- + Technology might, under special circumstances, be suitable for the situation
- Blank Technology unsuitable for the situation.

#### 3.2 Short list selection tool

The decision process for selecting of the most appropriate sanitation system for a particular site is very complex and cannot be comprehensively covered in a simple flow chart. Figure 1 provides a methodology for short listing technologies suitable for particular situations. This should be seen as a starting point for technology selection, other factors must be taken into consideration as mentioned in the table's key.

<sup>6</sup> This document focuses on the immediate and medium term. Not all longer term options are included.



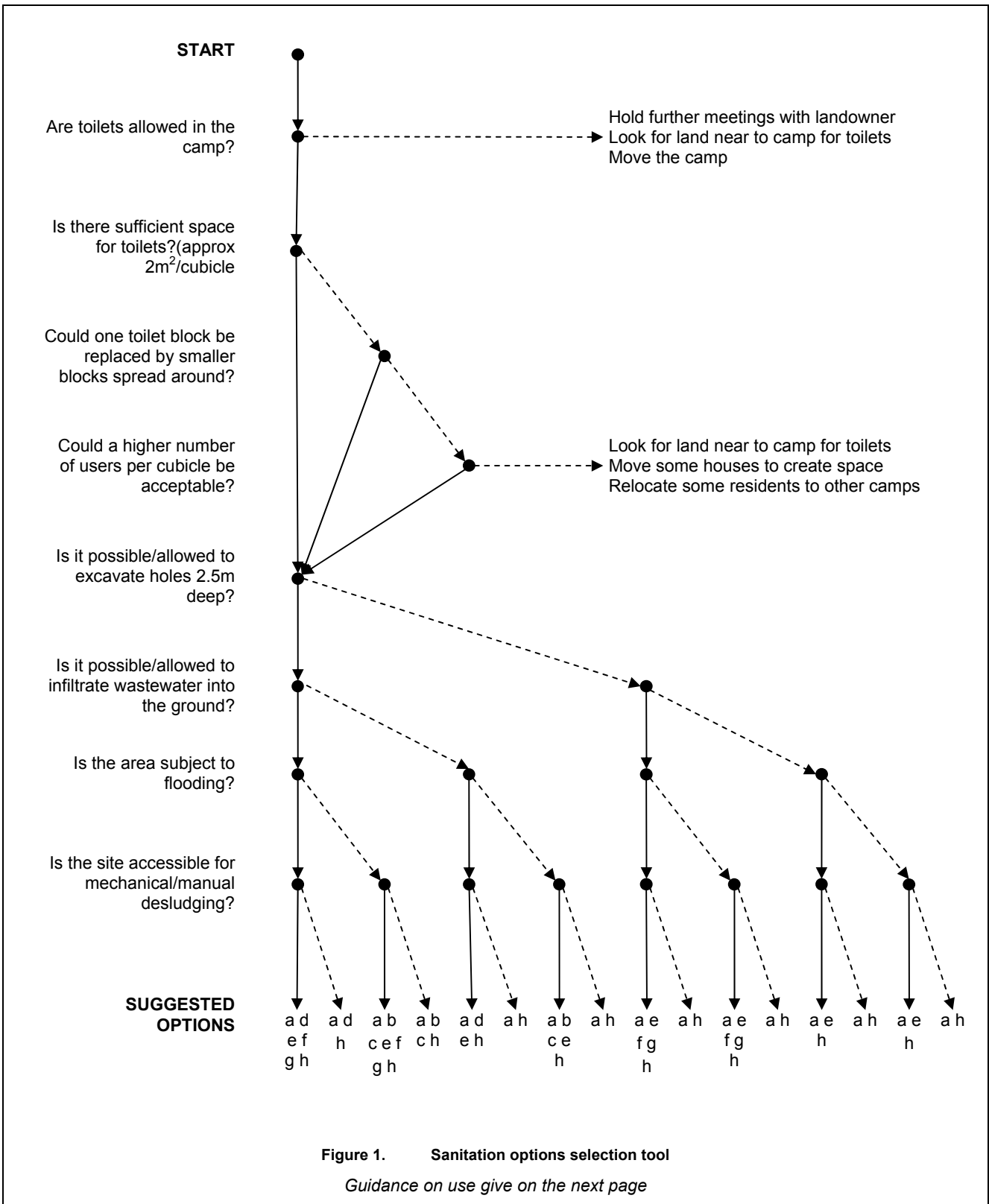

## EMERGENCY EXCRETA DISPOSAL STANDARDS AND OPTIONS FOR HAITI

---

### Key

Starting at the top, follow the arrows down the page, answering the questions listed on the left hand side.

-----▶ Follow this arrow if the answer to the question is NO

————▶ Follow this arrow if the answer to the question is YES

### Options

The options suggested at the bottom of the chart should be considered a short list. Further issues such as ground slope, security, operation and maintenance, local regulations and speed of set up will also have an effect on the final choice.

The letters in the 'Suggested Options' row relate to the following disposal systems

- a Biodegradable plastic bags (section 5.3)
- b Trench latrines – single use or emptiable (section 5.1)
- c Simple and ventilated pit latrines – also arborloos (section 5.2)
- d Raised simple and ventilated pit latrines (section 5.2)
- e Sealed storage tanks (section 5.4)
- f Septic tanks (section 5.6)
- g Aqua privies (section 5.7)
- h Urine diversion (section 5.5)

## 4. Toilets<sup>(2)</sup>

As far as the user is concerned, the toilet block and cubicle<sup>(3)</sup> are the most important parts of the excreta disposal system. If, for whatever reason, people do not use the toilet then the rest of the system is useless. Community views on what makes a toilet attractive vary greatly; even relatively small things can persuade users to go elsewhere. Much of this section is taken from Jones and Reed (2005). Although this book is focuses on the needs of disabled people, the suggestions make toilets accessible by most members of the community.

### 4.1 Getting there

If users can't reach the toilet, they can't use them! The issue of 'Getting There' can be divided into elements.

#### *Walking distance*

People will not walk far to use a toilet, particularly if they did not use them before the earthquake. Some such as the elderly, disabled people and pregnant women are unable to walk long distances. Therefore, the nearer the toilets are to the users the better. Table 1 specifies the maximum one way walking distance users should travel. There are also problems with placing toilets too close to users' homes. No matter how well public toilets are cleaned and maintained there is likely to be some smell. If possible keep public toilets at least 10m from individual homes. Individual household latrines can be closer.

#### *Access route*

Just because a toilet is close to the users does not mean that everyone can reach it. This is particularly true for vulnerable people who might have difficulty walking, need assistance to walk or be too weak to overcome large obstacles. Some key features that can make access routes widely accessible are:

- Access paths should be a minimum width of 120cm and preferably 180cm
- Paths should be as even and smooth as possible, preferably with a non slip surface. This will reduce the likelihood of trips, slips and falls – especially at night.
- Where possible keep slopes at a gradient less than 1:10 and provide a hand rail. This will help wheel chair users and others who have difficulty walking (Figure 2a).
- If steps must be installed make sure they are all the same depth and height. The vertical distance between steps should be between 15 & 17cm and the depth of the step between 28 & 42cm. A resting platform is required after every 18 steps. Always provide a hand rail (Figure 2b).
- Provide stable and level bridges to cross drainage channels
- In large camps, provide direction markers to the toilet blocks.



(a)



(b)

Figure 2. Examples of access ramps and steps

## 4.2 Block location and layout

The layout and location of public toilet blocks is heavily constrained by the conditions. Many sites in Haiti are very congested and have additional restrictions placed on them by land owners and user groups (see section 1.3). The final selection will always be a compromise but here are the main things to take into consideration:

- **Community preferences & convenience.** Identify the community groups intended to use the toilet block and discuss your plans with them before starting. In general they will probably prefer the toilet block close to the centre of their community but that may not be the case.
- **Space.** Toilets vary, but on average, the space required for a toilet block is approximately 1 square meter per cubicle. Access platforms, walkways and steps will double this figure
- **User access.** Review the pathways and roads in the areas to check that all members of the community can reach the block.
- **Maintenance access.** Many of the excreta disposal technologies being used in Haiti require vehicle access on a regular basis. Place the toilet block close to an access track suitable for the vehicles expected.
- **Access to water.** Some disposal technologies require a regular water supply. Check for access to a regular supply or ensure a water tanker can reach the block
- **Ground conditions.** If the excreta are to be disposed of or stored below ground, ensure the soil conditions are suitable. Check for the soil depth and stability, depth to water table and groundwater quality, ground slope and stability, etc.
- **Security.** Place toilet in a public area, away from possible hiding places.
- **Separate the sexes.** Provide separate toilet blocks for men and women with a physical separation between them. Common entrance passages and shared dividing walls made of canvas should not be used as women may feel threatened.

### 4.3 Getting in

A level platform outside the toilet entrance is important, particularly where a door is fitted (Figure 3). The level area should be at least 1.0m wide or 30cm greater than the door width (if the door opens outwards) (Figure 4). Platforms above ground level should always be fitted with a support rail 80 – 100cm high. A second lower rail may be needed for smaller children.

#### Security

Women and children are frequently concerned about toilet security. This is particularly true if using them after dark. It is traditional in many communities to defecate in the early morning and evening, just the times when there is most concern about being attacked. In a camp situation it is obviously impossible to overcome all concerns but there are a few things that can be done to improve security at public and communal toilets:

- Place toilets as close to the users as possible to reduce walking time;
- Place toilets in public places where there are lots of people about. Hiding them behind trees or out of sight increases security risks;
- Make sure there is an attendant on duty at the times when public toilets are in use.
- If possible provide lighting in and around the toilet block. This will also make the toilets easier to use, reduce accidents and promote the cleanliness of the block.



Figure 3. Poor toilet access on a urine diversion toilet in ?? camp

Difficult to climb steps and open door



Figure 4. Entrance platform for a raised latrines in ?? camp



Figure 5. Sheeting doors on a trench latrine in ?? camp

*This design does not provide privacy or security*



Figure 6. Timber framed door with simple internal lock on a urine diversion toilet in ?? camp

*The gap between the wall and the floor is not recommended*



Figure 7. Cubicle floor and walls of plastic sheeting in a single use plastic bag latrine in ?? camp

## 4.4 The toilet cubicle

The cubicle should be clean, light, safe, large enough for the users, appropriate for local customs and practices, and free from odour and flies.

### Floor area

For most purposes the cubicle floor area should be approximately 120cm deep x 80cm wide **provided the cubicle door opens outwards**. If it opens inwards then increase the depth to approximately 150cm.

Cubicles designed for vulnerable groups should be approximately 160cm wide

### Cubicle Height

The cubicle should be about 2.0m high with good ventilation at the top. A roof is necessary to keep out the elements and for privacy.

### Door

In the beginning, a simple door flap made of sheeting with a weighted base is satisfactory (Figure 5). As soon as possible this should be changed to a rigid door fitted with a simple internal locking device (Figure 6). Do not leave a space between the door and the floor as it reduces privacy and dignity.

Doorways may be as narrow as 45cm but a minimum free opening space of 50cm is recommended. Cubicles designed for use by vulnerable groups should have a minimum door opening width of 80cm

### Floor

Floors should be smooth and level and preferably made of wood, plastic or concrete. Plastic sheeting can be used as a temporary measure (Figure 7). Mud floors are not recommended as they become uneven and slippy when wet.



Figure 8. Corrugated plastic walls on trench latrines in ?? camp



Figure 9. Examples of hand rails

### **Walls**

Initially walls can be made of plastic sheeting as in Figure 7 but for longer term use solid walls of wood, or corrugated metal or plastic (Figure 8) are preferred.

A strong hand rail attached to help users get on and off the latrine is essential in cubicles for vulnerable users and preferable in all other cubicles (Figure 9).

### **Threshold**

The floor level in the toilet should be as near as possible to the level outside. A large step in can cause trips and falls, especially when leaving at night (Compare Figure 3 with Figure 4).

### **Privacy screen**

Women in particular prefer privacy when using latrines. A simple screen in front of the toilet block in addition to the doors will often meet this need. The main issue with privacy walls is security. Women must be sure that the design does not provide places for people to hide.

### **Construction and the environment**

The majority of emergency toilet blocks in constructed in Haiti have used a wooden framework. Wood is a flexible material, easy to work but not necessarily good for the environment. Much of the environmental degradation suffered by Haiti has been caused by the wanton destruction of its forests. Organizations should attempt, as much as possible, to use wood sourced from sustainable forests.

Alternatively use other construction materials such as the corrugated sheeting shown in Figure 8 or steel scaffold poles as shown in Figure 10.



Figure 10. Toilet framework of steel scaffold poles

### ***Prefabricated toilets***

A number of organisations are using prefabricated toilets. Some, such as those shown in Figure 11, are delivered complete and ready to use whereas others such as the ones shown in Figure 8 & Figure 12 are shipped flat packed.

The prefabricated cubicles made of twin wall rigid plastic sheeting shown in Figure 13 have not proven satisfactory in Haiti. They were not durable.

### ***Urinals***

There are very few urinals in Haiti. Discussions with implementing partners suggest that they are not a priority as people appear to prefer to urinate in private or use the toilets provided. Emergency urinals can be difficult to keep clean and are often a source of strong odour leading to complaints from nearby residents.

People should be encouraged to urinate in the toilets provided. This will centralize the collection and storage of excreta, reduce indiscriminate urination around the camp and add essential liquid to the stored excreta, making it easier to empty.



**Figure 11. Prefabricated toilets widely used in Port au Prince**



**Figure 12. Prefabricated flat packed toilet block installed by IFRC**



**Figure 13. Prefabricated flat packed twin walled rigid plastic sheet toilet block**





Figure 14. Examples of pedestals



Figure 15. Plastic squatting plates



Figure 16. Raised squatting pan



Figure 17. Block pedestal for disabled users

*Blocks would be covered in cement plaster. They are more comfortable than it appears!*

### ***To sit or to squat?***

There is no fixed rule as to whether to install sitting or squatting toilets. From a hygiene, simplicity and cost perspective, squatting toilets are undoubtedly better but this misses the point. The most important consideration is, will people use them? Two main factors come into play here; what are people accustomed to and what would they prefer? People from all levels of society have been affected by the earthquake and so different choices will be required for different groups.

Middle and upper class people are probably accustomed to using pedestal toilets and so that is what should be provided. People from the poorer areas of the city may never have had a toilet before the earthquake and if they did it is most likely to have been of the squatting type. Never the less, if asked what they prefer, they may well say a sitting type, as they believe them to be more modern. The problem is that some people who are unaccustomed to using pedestals will continue to squat, thus fouling the sitting area and making it unfit for others to sit on!

The decision has to be taken on a site by site basis. A general rule of thumb is to start with the assumption that a squatting pan is the most appropriate and see if the community can change your mind.

### ***Pedestals***

There are many designs of pedestals Figure 14 shows some of the designs currently in use in Haiti. All pedestal holes should have a tight fitting cover.

### ***Squatting pans***

Squatting pans are now commonly made of plastic or composite materials (Figure 15) as they are easy to install and clean. However they can also be made of concrete or wood. All defecation holes should have a tight fitting cover. Users prefer to face the door when squatting so make sure the plate is installed the right way round.

Squatting pans should not be raised above the floor level as shown in Figure 16. This is a very unstable position, especially for the elderly.

### ***Toilets for children***

Children find adult toilets too large and either foul them or refuse to enter the cubicle. Cubicles can be designed to meet the needs of children by reducing the size of the hole and changing the location of footrests (for a squatting pan) or moving the hole closer to the edge of the pedestal. Figure 18 shows the layout of a school toilet block showing different hole sizes for different ages of pupil.

Provide mothers of smaller children with disposable plastic bags and educate them place the faeces in the bag before disposing of it either in the toilet or a container specifically provided.

### ***Seats and squatting plates for vulnerable groups***

Notice that the end hole in Figure 18 has two columns of blocks replacing the foot rests. These are to allow disabled people to use the latrine independently (another illustration is shown in Figure 17). Use of pedestal toilets can be improved by the provision of more space in the cubicle and the installation of handrails.

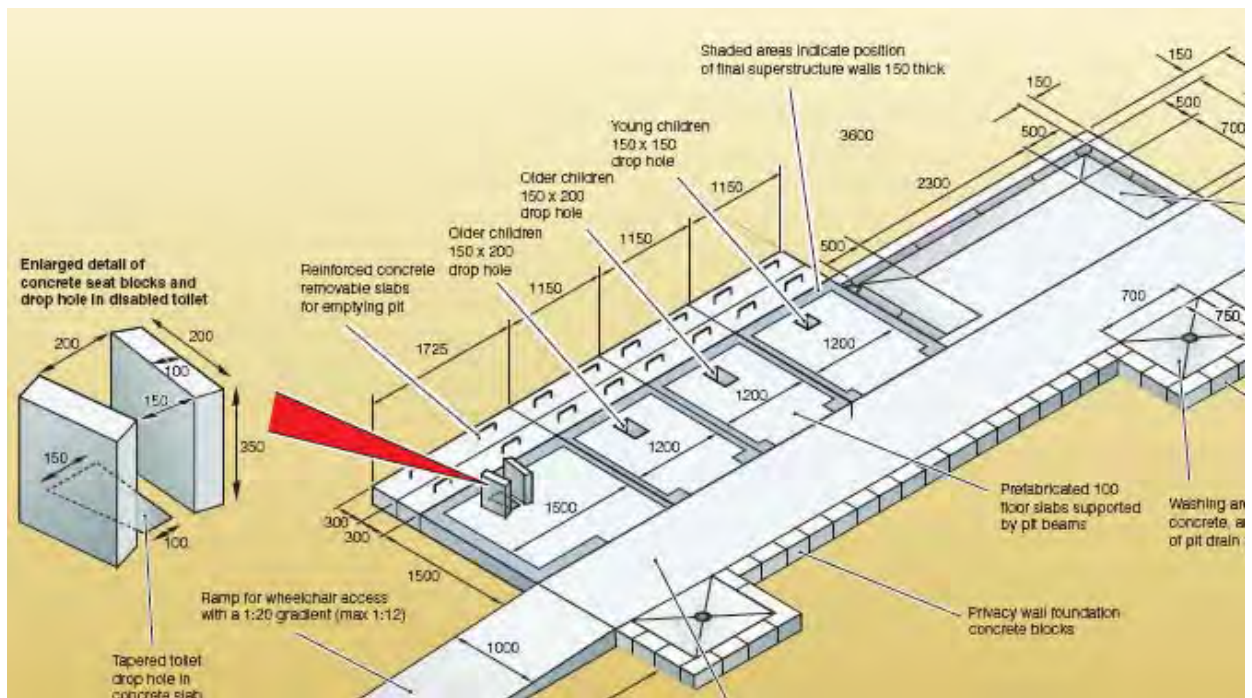

**Figure 18. Floor layout for a school toilet block (Part of a larger drawing)**

*Further details on school toilets can be found in Reed & Shaw (2008)*

## 5. Options for the storage of excreta



Figure 19. Digging trenches for toilets



Figure 20. Installing squatting pans over a trench



Figure 21. Pedestal toilets for trench latrine under construction



Figure 22. Prefabricated trench lining in ?? camp to support weak soils

### 5.1 Trenches

A number of organisations in Haiti have constructed trench latrines (Figure 19). They involve the siting of several cubicles above a single trench which is used to collect the excreta. Do not to construct too many latrines side by side as this may weaken to ground between the trenches, causing the trench walls to collapse.

The recommended maximum length of trench is 6m, providing six cubicles. Trenches are usually 2 – 4m deep and 0.8 - 0.9m wide but can be wider if the toilet block above is designed appropriately. At least the top 0.5m of the pit should be lined to ensure that the trench remains stable. Trenches that are expected to be emptied should be fully lined (Figure 22). A 1m wide plastic sheet laid on the ground around the trench will reduce problems with soil erosion when it rains.

After the trench has been dug, the quickest option is to put self-supporting plastic slabs straight over the trench (Figure 20). Alternatively pedestal toilets can be installed (Figure 21).

A 100mm ventilation pipe with its outlet covered by fly mesh should be fitted to each end of the trench to reduce fly and odour problems in the cubicles. A drainage ditch around the trench may be necessary to divert surface water.

**Advantages:** Cheap; quick to construct; no water needed for operation; easily understood.

**Constraints:** Unsuitable where water-table is high, pollution of ground-water is possible, soil is too unstable to dig or the ground is very rocky; often odour problems; cleaning and maintenance of public trench latrines are often poorly carried out by community user groups.

**More information:** Harvey (2007);

## 5.2 Pits

Simple pit latrines are by far the most common technology choice adopted in emergencies worldwide. In Haiti they are mainly used in small camps and in rural areas. They are simple, quick to construct and generally inexpensive (Figure 24). The pit should be as deep as possible (minimum 2m) and covered by a latrine slab. At least the top 1m of the pit should be lined to prevent collapse, and where the soil is suspected to be unstable the entire pit should be lined.

The floor can be fitted with a squatting plate or pedestal and should be raised above the surrounding ground level to prevent surface water entering the pit. The defecation hole must be covered to keep out flies and reduce odour. The addition of a ventilation pipe whose outlet is covered in fly mesh will enhance fly and odour control (Figure 25). Normally each pit is covered by a single cubicle but this can be increased to as many as four.



Figure 23. The Arborloo principle

The floor slab can be raised up to about 1m above ground level in areas subject to flooding. The pit must be lined and an earth embankment built around the pit to protect the lining from erosion.

A simpler design is the 'Arborloo' (Figure 23). An unlined hole about 1.5 – 2m deep is dug and covered with a squatting slab and surrounded by a simple plastic sheet shelter. When the pit is nearly full the shelter and slab are removed, the pit contents covered with earth and a tree planted in the middle. The tree grows on the nutrients in the excreta. This is a popular technology in some rural areas of Africa where it is linked to improving agricultural productivity for small scale farmers.

**Advantages:** Cheap; quick to construct; no water needed for operation; easily understood; possibly family latrine for resettlement camps.

**Constraints:** Unsuitable where water-table is high, there is the possibility of groundwater contamination, soil is too unstable to dig or ground is very rocky; often odour problems. Not recommended for regular use by more than 20 people a day; unsuitable for high density urban areas; social problems with maintaining toilets with shared pits.

**Further details:** Harvey (2007); Obika A (2004)

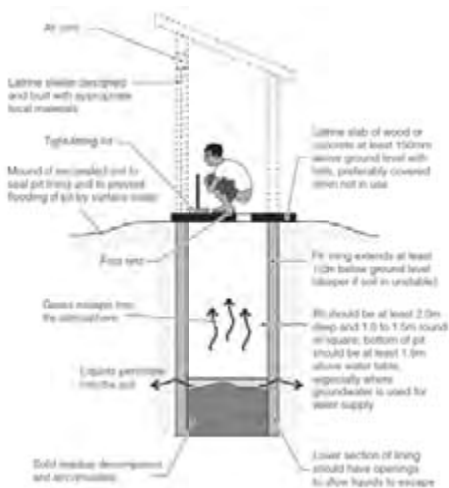

Figure 24. Simple pit latrine

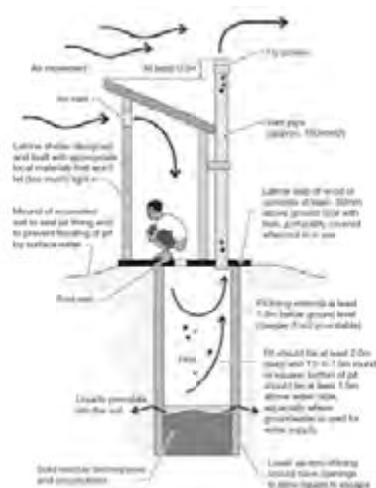

Figure 25. Ventilated pit latrine

### 5.3 Single use biodegradable bags

Single use plastic bags (sometimes called 'Packet Latrines') are an excellent immediate excreta disposal response. The bags, which must be biodegradable, sometimes contain enzymes to breakdown the excreta. They may also contain absorbent cloth to keep the faeces dry. There are various commercial options available but simple plastic bags will often be satisfactory in the early stages. These are sometimes referred to as 'flying' latrines since the packets can be thrown into a disposal pit or container.

The bags are usually placed under a pedestal in a container (Figure 26). After use, the bag is removed; the top tied and then placed in a sealed container for disposal. The pedestal can be placed anywhere that provides suitable privacy for the user.

Some designs are intended for direct use, requiring no seat. The bag is held directly against the bottom and the top sealed after use (Figure 27).

Other designs are intended for multiple uses before replacement. These larger bags (like bin liners) can hold more excreta but this makes them more difficult to handle and requires the operation to be carried out by a cleaner rather than the user.

Effective management of the system is crucial, and requires ongoing monitoring and appropriate hygiene promotion. Appropriate disposal sites for the used bags must be developed immediately and an active campaign initiated to inform community members of the benefits of this type of disposal system and how to use it correctly. Basic consultation with the community is necessary before implementing such a system.

**Advantages:** Lightweight and easy to transport; rapid setup; low cost; may be used where space is severely limited or in flooded areas; suitable for people who cannot leave their homes to visit a public latrine; easy to move if camp moves.

**Constraints:** Method may not be acceptable to affected population; hygienic collection and disposal of used bags essential; constant supply of replacement bags available at all times; only a short term response.



Figure 26. Examples of single use bag systems in Haiti



Figure 27. Single use, no seat



Figure 28. Holding tank in a prefabricated toilet unit.



Figure 29. Single cubicle tanks



This tank was buried but floated after rain. Note 4 holes in top



Figure 30. Multiple cubicle tanks

## 5.4 Holding tanks

Pre moulded plastic water tanks make excellent containers for storing excreta. They come in many sizes but the most commonly used in Haiti are the 250 and 500 gallon (968 litres & 1,937 litres). The tanks are placed at ground level or partially buried, with the toilet block built on top (Figure 29). Holes cut in the top of the tank, are located directly below the drop hole and a chute (often a large bucket with the bottom cut out) placed between the two. The 250gall containers are connected to individual cubicles whilst the 500gall ones are attached to four cubicles (Figure 30). Larger tanks have also been used but it is not clear if the additional size is of any benefit. Every tank must be fitted with a ventilation pipe, complete with fly mesh, to control odour and flies. Emptying is usually via one of the defecation holes.

A number of organisations in Haiti are piloting this type of storage system but at the time of writing, most were very new, making it difficult to predict longer term problems.

A large number of smaller prefabricated portable toilets have been installed around Port au Prince (Figure 11 & Figure 28). These are basically the same, having a holding tank directly below the pedestal seat. The tank capacity is very small, requiring the tank to be emptied daily. Chemicals are commonly added after each emptying, mainly to reduce odour and to make the tank contents look less offensive.

### Sizing the tank

In general, the larger the holding tank the better. This is because large tanks will require emptying less often and the emptying process is more cost effective. Where commercial vacuum tankers are used for emptying the amount charged is almost independent of the amount collected. However, care should be taken not to use tanks that are much too large for the amount of wastes they will receive. If it takes too long to fill the tank, the sludge will digest and consolidate on the bottom, making it very difficult to empty. There is insufficient knowledge at present to provide guidance on how to select the best size tank; organisations must experiment to determine the best setup.

If the size of vacuum tanker to be used is known in advance then tanks, or groups of adjacent tanks can be sized so that their total volume closely matches the volume of the tanker used for emptying.

**Advantages:** Fabricated from local materials; no contamination of the surface or groundwater; tank easy to empty; larger tanks provide extended storage thus increasing the time between desludging; suitable for almost any site condition; easy to move if camp moved.

**Constraints:** Long term effectiveness unknown; tanks must be mechanically emptied, limiting the options for anal cleansing materials; good operation and maintenance essential; partially buried tanks may float if area floods or there is a high water table; thin walled tanks may implode due to soil pressure when partially buried; prefabricated portable toilets have high operational costs and it is not known if the chemicals added affect the bacterial activity in treatment plants; elevated cubicles are more difficult to access for vulnerable people.

**Further details:** Harvey (2007)



Figure 31. Urine diversion pan



Figure 32. Collection system

*Black pipe takes urine to soakaway*

## 5.5 Urine diversion

The main reason for separating faeces from urine is to recover the nutrients, which can then be dealt with separately. The process also reduces the volume of excreta stored and its moisture content. Effectively managed units may also give off less smell and suffer less with fly breeding. Nutrient recovery is covered in more detail in Chapter 8.3

A specially designed pan is required to separate the urine from the faeces at source and users have to be educated in how to use them.

Sometimes the faeces are stored and treated in a large container directly below the toilet. In Haiti however, they are collected in smaller containers and transferred to a nutrient recovery site elsewhere.

Generally (but not always) ash, dry soil or saw dust are added to the faeces to absorb excess moisture. The urine is either collected in containers or allowed to soak into the ground

**Advantages:** Faeces can be handled in a solid form, simplifying transport; provided urine is collected in containers there is no ground or water contamination; valuable nutrients in excreta can be recovered; good for smaller camps with a strong community structure.

**Disadvantages:** Users must be educated in the use of urine diversion pans and to add additional organic materials after use; dry faeces must be handled and transported manually, increasing potential contact with pathogens; there must be a demand for the recovered nutrients; no documented examples of the technology being widely used in emergencies.

**Further reading:** Harvey (2007)

## 5.6 Communal septic tanks

Septic tanks are an established method of storing and partially treating human wastes. A sewer pipe is laid beneath the cubicles in a toilet block to collect the wastes from the toilets. The sewer carries the wastes to a sealed tank(s) where the solids settle to the bottom and undergo decomposition. The liquid is partly treated by natural chemical and biological activity before leaving the tank. The liquid overflow normally soaks into the ground (Figure 33).

Since people in Haiti do not use water for anal cleaning, additional water must be added to the system to flush the faeces along the sewer and into the tank. A periodic flushing from a 20 litre tank fitted to the end of the sewer will suffice. Only water or soft toilet tissue can be used for anal cleansing unless the material used is collected separately.

In an emergency, the conventional septic tank can be replaced by a prefabricated water tank or, as shown in Figure 34, two 15 cu m water bladders. A similar system to this was used some years ago to treat the waste from a 20 cubicle toilet block serving 2000 people a day.

Septic tanks are also commonly used for excreta disposal from schools, hospitals, offices, and high income houses where sewerage systems are not available.

**Advantages:** Established technology that can be designed to serve a variety of population sizes; reduces the volume of sludge; disposes of sullage<sup>7</sup>.

**Disadvantages:** Additional land area needed for the septic tank and disposal system; additional water necessary for flushing; unsuitable for areas with a high water table, rock close to the surface or impermeable soils; possibility of groundwater contamination.

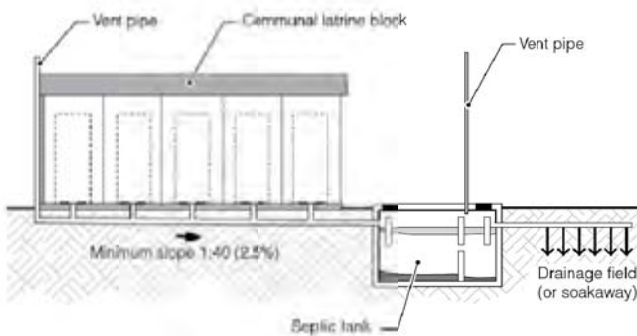

Figure 33. Standard septic tank serving a block of public toilets

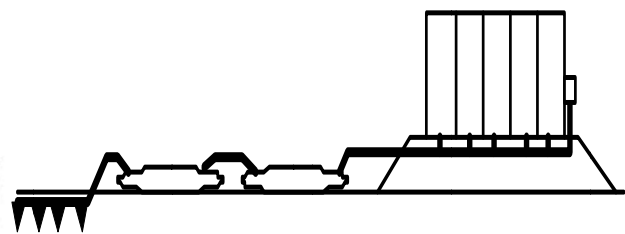

Figure 34. Two bladder septic tank serving a block of public toilets

<sup>7</sup> Sullage is waste water from kitchens and bathrooms other than that coming from toilet pans.



## 5.7 Communal aqua privies

An aqua-privy is a toilet block constructed directly above a septic-tank (Figure 35). They are suitable for locations where pit latrines are socially or technically unacceptable but the volume of sullage is small.

The system consists of a large water tight tank constructed directly below the toilet cubicles. A single overflow pipe in the side of the tank controls the water level and carries excess liquid into a nearby soakage pit or trench. The toilet cubicle may be fitted with a pedestal or squatting pan. In either case a 10 cm vertical pipe is fitted below that extends about 7.5 cm below the maximum water level.

The tank is initially filled with water so that when people use the toilet their excreta falls directly into it. The 7.5 cm depth of water in the drop pipe prevents flies and odour entering the cubicles. A small amount of water must be added to the tank from time to time to keep it full and to partially dilute the incoming sludge. This can be achieved by diverting the hand washing waste water into the tank or providing bathing/laundry facilities close by and using their runoff to top up the tank.

In emergencies, the watertight tank could be fabricated from a large plastic water tank as shown in Figure 36.

Aqua privies are also appropriate for excreta disposal in schools and prisons where it is not possible to connect to a sewer network.

**Advantages:** Very low water requirement; reduced odour; easy to clean; extended period between tank emptying.

**Constraints:** Essential to add sufficient water to keep tank full; unsuitable for solid anal-cleansing materials; potential groundwater pollution hazards from overflow.

**Further details:** Harvey (2007)

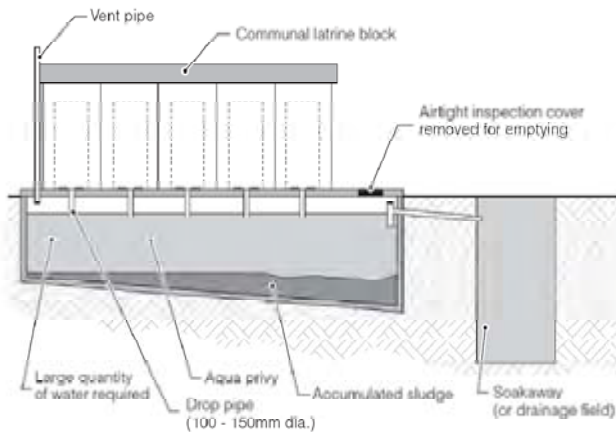

Figure 35. Typical communal aqua privy

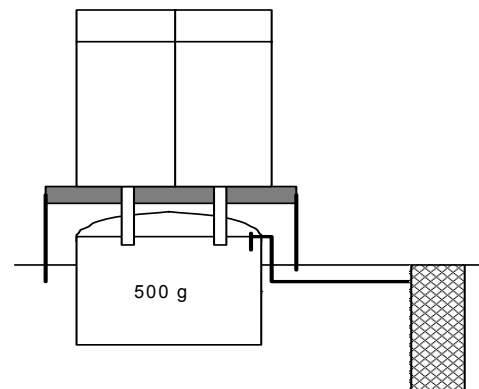
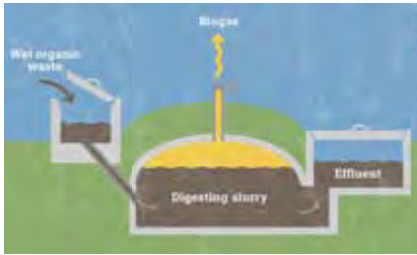

Figure 36. Emergency communal aqua privy constructed using a standard water tank

## 5.8 Biogas



**Figure 37. Typical biogas unit**

*A block of toilets can be replaced by the wet organic waste tank.*



**Figure 38. Biogas plant in Port au Prince**

*Small pipe in centre of picture pipes the biogas to the kitchen cooking stoves*

If organic waste is allowed to decompose in an environment free of oxygen it will give off a gas. Given the right temperature and mix of wastes, much of the gas will be methane, which is flammable. If sufficient volumes of waste are collected regularly, the volume of gas produced will make its collection and use viable. The mix of gases produced is called 'Biogas' (Figure 37).

Biogas generation has been incorporated into domestic latrines in a number of countries with mixed success. The gas produced is used for cooking and lighting. A mixture of human and animal excreta is commonly used but there are also successful examples of plants relying entirely on excreta from public toilets.

Biogas plants typically store the wastes for about 30 days. This removes some of the pathogenic organisms but by no means all. Further treatment of the wastes is necessary before it is free of pathogens.

Biogas plants are very expensive to build and difficult to operate. Poor maintenance leads to loss of gas production and blockage of the digester tank with solids. They are only appropriate in communities with a commitment to recycling organic wastes. There are no published examples of biogas plants being widely used as an emergency sanitation response.

There is only one known biogas unit in Port au Prince (Figure 38), taking the wastes from around 250 people a day, although the plant is designed to handle 1000 people. It was constructed before the earthquake.

**Advantages:** Partially treat the wastes, reducing the volume for final disposal; produces a flammable gas stored as an energy source.

**Disadvantages:** Expensive to build; effluent requires further treatment before disposal; difficult to operate and maintain; unsuitable for many anal cleansing materials; not an emergency response.

## 6. Tank emptying

The shortage of land, poor ground conditions, constraints applied by landlords and environmental restrictions imposed by local municipalities means that many (if not most) of the latrines in Port au Prince and the other affected areas in Haiti have some form of holding tank for excreta that must be periodically emptied. Unfortunately the choice of technology for doing this is limited by the availability of equipment and the technical difficulties involved in handling excreta.



Figure 39. Vacuum tanker emptying trench latrines



Figure 40. Water jetting to liquefy trench latrine wastes



Figure 41. Powered diaphragm pump



Figure 42. Trailer mounted storage tank

### 6.1 Mechanical pumps

#### *Vacuum pumps*

Vacuum pumps reduce the air pressure inside a storage tank (i.e. they pump air). A pipe connected to the storage tank is fed into wastes to be pumped and the difference in pressure between the tank and the atmosphere draws the wastes into the tank. The advantage of this method is that no waste products pass through the pump, meaning solid materials can be moved without damaging the pump.

This is the normal type of pump fitted to a standard vacuum tanker (Figure 39). Vacuum pumps are most suited to pumping liquids so water often has to be added to the wastes before they can be moved (Figure 40).

**Advantages:** Large capacity; high pumping rate; will pump small solids.

**Disadvantages:** Extremely expensive; complex vehicles; most vehicles are too large for use in congested areas<sup>8</sup>; cannot pump large solids, including plastic bags and stones.

#### *Diaphragm pumps*

A small metal tank is sealed across the top by a flexible rubber disc (the diaphragm). The tank has two openings on opposite sides, protected by simple flap valves that only allow liquids to move in one direction. The diaphragm is connected by a series of levers to an engine so that when it is working, the diaphragm is pushed up and down (Figure 41). The inlet opening on the tank is connected via a pipe to the wastes to be pumped. The outlet opening is connected via another pipe to some form of portable storage tank (Figure 42)

**Advantages:** Very powerful; pump thick materials short distances; manoeuvrable in confined spaces; easy to operate and maintain.

**Disadvantages:** Low pumping rate; cannot pump solids such as stones and sticks.

**Further details:** SANDEC in Switzerland have produced a range of articles related to all aspects of faecal sludge collection, transport and treatment. [www.sandec.eawag.ch](http://www.sandec.eawag.ch)

<sup>8</sup> Specialist vehicles have been developed in a number of countries to work in congested areas such as low income housing areas. They are much smaller than commercially manufactured vacuum tankers (and much cheaper) but tend to be slow and have a small tank capacity.

## 6.2 Hand operated pumps

### *Vacuum pumps*



Figure 43. Manually operated vacuum tanker

A number of countries have experimented with hand operated vacuum pumps, the most well known being the MAPET pump in Tanzania. The storage tank is mounted on a trolley so that it can be pushed from site to site. The vacuum is supplied by a simple piston pump (similar to a bicycle pump) with valve arrangements that cause it to lower the pressure inside the storage tank (Figure 43).

The system worked well in Tanzania for a while but was not a commercial success. It will only pump liquids containing little or no solids.

### *Diaphragm pump*



Figure 44. Typical manual diaphragm pump

These are very similar to that described in section 6.1 except that they are manually operated rather than motor powered. The engine is replaced by a long handle that the operator(s) move up and down. A lever mechanism connects the handle to the diaphragm which, in turn, also moves up and down.

**Advantages:** Cheap; very simple design; easy to repair

**Disadvantages:** Replacement diaphragms not easy to find; slow pumping rate over short distances; sludge must be in liquid form.

### *Manual desludging handpump (MDHP)*



Figure 45. MDHP

Developed in South Africa as a simple device for emptying pit latrines and septic tanks (Figure 45). It consists of a 1 – 2m length of 100mm straight pipe. The bottom is open and a short 90 degree bend fitted at the top. The top of the vertical pipe is sealed except for a small hole in the centre of the cap. A short length of hose is connected to the end of the bend to carry the wastes to a nearby container.

A long metal rod is inserted through the hole in the top cap. The top of the rod has a 'T' shaped handle. The bottom is fitted with a hinged foot valve (Figure 46).

The pipe is pushed into the pit sludge as far as possible. The rod is then pushed a short way into the sludge inside the pipe. The metal flap valve retracts so that it can cut through the sludge. As the rod is raised the flap valve closes and the sludge above is lifted. When it reaches the top it is forced around the bend, along the hose and into the receiving tank.

**Advantages:** Very simple, can be made locally; can work in confined spaces; pumps thick sludge

**Disadvantages:** Hard work and very slow; highly labour intensive; easily blocked with stones and plastic bags; not widely tested.

**Further details:**

<http://www.oxfam.org.uk/resources/learning/humanitarian/mdhp.html>



Figure 46. MDHP foot valve

### 6.3 Manual emptying

***While very common in Haiti, manual emptying of excreta cannot be recommended. It is highly dangerous and a serious health hazard to those doing the emptying and the community around the tank being emptied***



Figure 47. Manually emptying a pit latrine

*Photograph not taken in Haiti*

In Port au Prince, most latrines have been emptied manually by a specialist community known as the 'Bayakou'. This secretive community usually works at night and insists on no one observing them. The emptying methods are thought to be very unhygienic, with workers standing in the excreta whilst removing it with buckets and shovels (Figure 47).

Reports suggest that a team of Bayakou can empty a 50 cu m tank of excreta in 2 – 3 nights.

Relief and development agencies have a responsibility for the health and safety of the people they employ. Therefore, if they intend to use this method for emptying latrines they must provide the workers with protective clothing such as boots, gloves, overalls, face mask and safety hat. They should also supply the appropriate tools. Ideally this will be a powered or manual sludge pump (see previous sections). Failing that, buckets, shovels and hauling rope. The agency must also supervise the workers to protect them against major hazards.

### 6.4 Reducing sludge volume

A number of agencies are experimenting with adding chemicals to latrine sludge. These chemicals are of two general types:

- Sludge digesting enzymes to reduce the volume and thickness of the sludge in the storage tanks prior to emptying; and
- Insect controlling agents, mainly for stopping the nuisance and health hazards associated with fly breeding.

Both these groups of chemicals are being developed to tackle issues related to the storage and handling of sewage sludge in developed countries.

At least one agency has indicated positive results from using enzymes to liquefy compacted sludge prior to pumping. They also observed a noticeable reduction in odour from the toilet block after the enzyme was added. Other organizations are still carrying out trials.

International research on the use of these chemicals in the types of environment currently found in Haiti are on-going but to date there is no evidence to show that they have any effect on fly breeding or freshly deposited excreta.

There is also no independent information about their long term environmental effects.

It is recommended that these chemicals are not used in Haiti unless additional positive evidence becomes available.

## 7. Sludge transport



Figure 48. Vacuum tanker

### 7.1 Vacuum tankers

The vacuum tankers used to empty toilet storage tanks also transport the faecal sludge to the disposal site (Figure 48). Whilst this is convenient it ties up valuable equipment.

Separating the pumping operation from the sludge transport, such as shown in Figure 41 & Figure 42, allows more effective use of the pump as it can work with multiple tankers.

Vacuum tankers are complex machines requiring regular maintenance and ready access to spare parts. Research on tanker operations in other countries has shown that they often run at a loss because of poor financial control.



Figure 49. Emptying waste from urine diversion toilet



Figure 50. Dedicated emptying vehicle for urine diverted waste

### 7.2 General garbage trucks & other vehicles

Wastes from urine diversion toilets are dry and could be mixed with general household garbage, provided the vehicle operatives were properly protected from infection by wearing boots, overalls, gloves, safety helmet goggles and a face mask. In general, in emergencies, containers for storing the faeces are quite small and can be handled manually (Figure 49).

Similarly, the used single and multiple use defecation bags can also be mixed with general garbage.

If large amounts of excreta are to be collected, a dedicated vehicle is more appropriate (Figure 50). Some defecation bags are however likely to burst during transit so vehicles must be waterproof and preferably be able to tip for emptying

**Further details:** SANDEC in Switzerland have produced a range of articles related to all aspects of faecal sludge collection, transport and treatment. [www.sandec.eawag.ch](http://www.sandec.eawag.ch)



Figure 51. Tipping trailer!

## 8. Treatment and disposal of excreta

**Further reading:** SANDEC in Switzerland have produced a range of articles related to all aspects of faecal sludge collection, transport and treatment. [www.sandec.eawag.ch](http://www.sandec.eawag.ch)

### 8.1 Burial



Figure 52. Pit desludging

In rural areas, where population densities are low, the most common disposal method for human excreta is burial.

Temporary pit and trench latrines are usually taken out of use when the contents are 0.5m from the surface. The superstructure is removed and placed over a new excavation. The partially full pit or trench is filled to ground level with some of the originally excavated soil. It is usual to mound the soil on top of the excavation as the soil level will drop as the excreta decomposes and loses its entrained water.

If the pit or trench is designed to be emptied (i.e. it is fully lined) then a temporary pit is dug nearby and the partially decomposed excreta transferred from one pit to another. The temporary pit is then backfilled with soil and excreta allowed to naturally decompose. Workers involved in the manual emptying of pits/trenches must be provided with appropriate tools and protective clothing (Figure 52). See section 6.3 for more details

**Advantages:** Simple and low cost; effective long term disposal method.

**Disadvantages:** Unsuitable for high density areas; health and pollution hazards.

### 8.2 Garbage site disposal

Disposing of excreta on garbage sites has a long history. Trenches, approximately 1m deep are dug in compacted, decomposed garbage. Excreta are poured into the trench until it's about half full. The trench is then backfilled with garbage. Trenches are dug in advance to accommodate one day's volume so that excreta are not left exposed overnight.

In Haiti, large steep sided pits have been dug in the garbage to store the excreta (Figure 53) but they have been over filled and left un-covered. These pits are highly dangerous as they are largely full of liquid and the wind-blown garbage that has landed on the surface makes them very difficult to see.



Figure 53. Excreta disposal pit in Port au Prince garbage site

*The pit is too big & has been completely filled with excreta so can't be covered*

**Advantages:** Simple and effective way of disposing of excreta, especially if trench digging and backfilling is mechanised.

**Disadvantages:** Adds to the leachate that may seep from the garbage tip; volume limited by the size of the garbage tip – usually only a temporary measure; large liquid content of the sludge slow to infiltrate into the surrounding garbage.



Figure 54. Sludge drying bed

### 8.3 Sludge drying beds

Sludge drying is a traditional method of reducing sludge volume. The sludge is poured into shallow tanks partially filled with sand (Figure 54). The liquor seeps into the sand and is collected at a low point for further treatment. The remaining sludge gradually dries (takes about 3 weeks), after which it is dug up and either composted or buried on garbage sites.

**Advantages:** Capable of handling large volumes of sludge; potential resource for recycling

**Disadvantages:** Still have to dispose of the very strong liquor (possibly use constructed wetlands); not very efficient during the wet season as the sludge doesn't dry; no experience of this approach in Haiti.

### 8.4 Co-composting



Figure 55. Freshly made compost heap in ?? camp

*The pallets protect it from surface runoff*

Under the right conditions, human faeces can be mixed with other organic material and composted to produce a basic fertilizer. The process requires careful control of the moisture content and the nutrient balance. It is commonly practiced in conjunction with urine diversion toilets (see section 5.5).

The mixture of faeces and organic material is heaped on a dry level surface and protected from rain (Figure 55 & Figure 56). The heap is turned periodically and urine added to control moisture content. After about 90 days the wastes have fully decomposed and are safe to use as a general fertilizer with no health risks.

In larger enterprises the dry excreta is mixed with freshly sorted organic garbage at a central site. This system is capable of producing large quantities of compost.

The unused urine can be diluted and used directly as a liquid fertilizer.

**Advantages:** Produces a safe useful final product. No contamination of the environment.

**Disadvantages:** Needs a large area of land; process must be carefully monitored to prevent health hazards; needs a demand for the final product; only a very small pilot unit installed in Haiti; not an emergency response.



Figure 56. Compost heaps covered to keep out rain



## 8.5 Waste stabilisation pond

Waste stabilization ponds are a simple and effective system for treating wastewater. The process consists of a series of ponds of varying depth through which the wastewater passes. The number of ponds varies but they are generally divided into three groups (Figure 57).



Figure 57. Conventional WSP layout

Waste stabilization pond design is complex, depending on the strength and volume of wastes to be treated, and local meteorological conditions.

### Anaerobic ponds

Are the first ponds in the series and generally around 3 metres deep. Solid material in the incoming waste either settle to the bottom or floats on the surface. Anaerobic<sup>9</sup> bacteria naturally present, break down the organic waste, producing gas and liquids. The residual solids gradually build up on the bed of the pond. The liquid part of the waste also undergoes treatment anaerobically before overflowing into the next pond. Periodically the sludge on the bottom of the pond has to be removed. It can be dried and then buried.

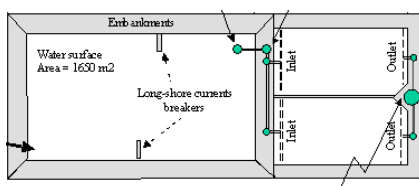

Figure 58. Typical two pond WSP system

### Facultative ponds

These ponds are 1 – 2m deep and cover a larger area than the anaerobic ponds. Their purpose is to continue the reduction in organic material in the liquid and provide an environment in which pathogens cannot survive. The liquid at the bottom of the pond is treated anaerobically whilst the that at the surface is treated aerobically<sup>10</sup>. Wind action and temperature variation regularly circulate the liquid so that both processes act on all of it.

### Maturation ponds

These take up by far the largest area. They are 0.5 – 1.0m deep and provide an environment where aerobic bacteria and other larger organisms can complete the treatment process.

### Treatment of faecal sludge

Waste stabilization ponds were originally developed for the treatment of sewerage but faecal sludge has commonly been added without causing operational problems. Ponds specifically for the treatment of faecal sludge are less common because the sludge is much stronger than sewerage and thicker. Some examples do exist and appear to work satisfactorily (Figure 58)

**Advantages:** Simple to construct, operate and maintain; very stable treatment process producing a good effluent; work well in similar climates to Haiti

**Disadvantages:** Complex design; requires a large land area; design criteria for faecal sludge not well developed; no experience of this technology in Haiti.



Figure 59. Discharging faecal sludge into WSPs

<sup>9</sup> Anaerobic bacteria survive in an environment where there is no free oxygen.

<sup>10</sup> Aerobic bacteria require the presence of free oxygen to survive. This may be in the form of a gas or dissolved in the liquid.

## 8.6 Constructed wetlands



Figure 60. Cross section through a constructed wetland

Constructed wetlands are sealed tanks holding a gravel bed with soil on top. Wetland plants are planted in the topsoil and sewage effluent slowly percolates through the gravel bed. The roots of the plants grow down into the gravel to collect nutrients from the sewage and thus purify the effluent (Figure 60).

Only one example is thought to exist in Port au Prince (Figure 62) and this is yet to be operational.

**Advantages:** Natural process for treating wastewater and producing a commercial crop.

**Disadvantages;** Selection of plants and design of the treatment process specific to particular sites. Wastewater must be treated to remove settle able solids before application; final effluent requires further treatment; only one pilot plant in Haiti, not currently commissioned; not an emergency treatment process.



Figure 61. Wetland under construction



Figure 62. Wetland in Port au Prince taking wastes from Biogas plant



Figure 63. Established constructed wetlands

## 9. Hand washing facilities

Hand washing facilities are an essential element in the prevention of the spread of excreta related diseases. This is particularly important in emergencies when populations are under stress and living in abnormal circumstances. Table 3 set out the key elements essential for good hand washing provision in Haiti.



### 9.1 Designs

Hand washing facilities come in many shapes and sizes (Figure 64 and Figure 65). Any design can be used provided it meets the following criteria:

- **Hand washing facilities must be located conveniently for all users.** Hand washing after using the toilet is not a customary activity in Haiti. Hygiene promotion activities can encourage people to wash their hands but this will only become a regular practice if the facilities are readily available. Place the facilities as close as possible to the toilets, preferably so that users must walk past them as they leave the toilet.
- **Consider the needs of all users.** Toilets are used by men and women, the very young and the very old. Place the facilities in such a way that all users can easily reach them. Consider having multiple water dispensers at the same water point to cater for different people's heights.
- **Provide clean water for hand washing.** Water for hand washing does not need to be clean to be effective in removing bacteria and waste products from the skin. However, dirty hand washing water is not acceptable to users and will dissuade them from using the facilities.
- **Provide simple to operate dispensing points** (see Table 3). The dispensing point is the part of the hand washing device that users use. It must be simple, robust, easy to clean and non drip.
- **Make sure there is always water in the device.** If users cannot rely on their always being water available for hand washing they will quickly lose confidence in the facility and stop using it.
- **Always provide soap.** Soap is an essential part of hand washing. Water alone will not clean the hands. Any form of soap will do but generally hard soap is more durable than liquid soap<sup>11</sup>. Providers frequently complain that users steal the soap and have devised many ingenious methods for preventing theft.



Figure 64. Examples of hand washing devices used in Haiti

<sup>11</sup> In many parts of the world, people eat with their hands rather than use cutlery. If this is the case in Haiti, more consideration must be given to the soap provided. Highly scented soap will impregnate the hands and may influence the taste of the food eaten. Low or non scented soap is much preferred.



**Figure 65. Oxfam prototype foot operated hand washing device with drain and container for waste water**

## **9.2 Waste water disposal**

Most of the water used for hand washing will fall to the ground after it has been used. If nothing is done to dispose of the waste water properly, the area below the hand washing point will become wet, muddy and slippery with soap.

If there is time, build a small cement apron below the water point to catch the water and divert it to a nearby drain, soakaway or holding tank. The apron can then be regularly cleaned to prevent a build up of soap deposits. Alternatively, fit a bowl or sink below the dispensing point to catch the waste water before it reaches the ground.

Alternatively, dig a small pit and fill it with stones. This will absorb the waste water and keep the area dry. If this is not possible, make sure there is a drainage channel from the water point to carry away the waste water.

## 10. Exit strategies

Most of the international (and national) relief agencies involved in the delivery of emergency sanitation in Haiti will eventually want to stop. To comply with the standards set out in this document they must have a viable exit strategy (Table 1). The reason for this is obvious – most of the toilets being constructed are public or communal (see section 2.2 for the difference between these two), thus requiring some form of structured maintenance regime. If the maintenance regime collapses after the agency leaves the toilet will quickly become dirty or blocked, and people will no longer use it. A properly thought out plan and strategy for dealing with when agencies leave is therefore essential to the sustainability of the services they have provided.

Exit strategies are never easy and there are no fixed solutions but a few suggestions are described below. As you will see, most of them are not rapidly implemented. They require advanced planning and usually an element of training and funding.

### 10.1 Close the toilet

If all the people have left the temporary camp then the toilets are no longer needed. The site should be returned to the condition it was in prior to the intervention. All structures should be removed and pits filled in.

### 10.2 Hand over to the community

It is likely that the routine operation of public toilets is already been undertaken by local community groups. They may be managing the toilets independently of the implementing agency but this is unlikely. Cost outlays such as desludging, the provision of cleaning agents and anal cleaning materials, and even the payment of guards and cleaners are most likely still being funded by the implementing agency.

It may be possible to formalize ownership and divide the financial outlays between a number of parties. Formally handing over ownership of the toilet to the community by the signing of an official document can raise a community's willingness to maintain shared facilities. They will have to find ways of raising the funds to pay cleaners and guards but this is usually a small amount and affordable by poor communities if they think it worthwhile. It may be possible to transfer, at least in the medium term, the cost of desludging to a third party such as the Government of Haiti or a UN organisation. Desludging is the major financial outlay related to operating a public toilet. If this can be supported by another organisation then there is a good chance of keeping the facilities operating. Other costs such as for cleaning agents and anal cleaning materials may be affordable by the community but the amount is relatively small and it is probable that another organization may support this in the medium term.

Even if this approach looks possible there will still be a need for community mentoring and support. Communities left to their own devices at such a vulnerable time are very likely to fail as they do not have the management skills or social cohesion to deal with all their problems independently. A local development based organisation should be retained to provide the backup management and logistical support the community will need. That organisation will, of course, require its staff to be properly trained in the necessary skills and techniques and will probably need start-up funds to support their efforts.

### 10.3 Hand over to a private contractor

There are examples in Port au Prince of individuals paying to use toilets. Where user numbers are high, this may be an option worth considering. A toilet block run for profit has some advantages over communally managed blocks. The profit will motivate owners to keep latrines clean and in good condition to encourage people to continue using them. Private facilities are also easier to monitor and regulate as there is a clear owner.

However, privatizing toilets is not without its problems. The main one relates to the managerial skills of the new owner. Existing business people may be interested in taking over toilet blocks but the profit margin is likely to be fairly low. They will be more attractive to small scale local entrepreneurs or community groups. For these to be successful they will require training, not only in the proper operation and maintenance of the toilet, but also in good financial management and book keeping.

Again it is essential to make arrangements for back up support and mentoring by a competent organisation until the new owners have proven themselves able to run the toilets effectively

#### **10.4 Hand over to another NGO**

Where communities are dysfunctional and unwilling to take responsibility this may be a good option. Haiti is blessed with a wide range of local NGOs, many of whom have worked in sanitation (but maybe not urban sanitation). With proper training and resourcing these organisations can take over the management and operation of public toilets.

#### **10.5 Give them to the Government**

The provision of a clean and sanitary environment is often the responsibility of Municipal Councils. With this in mind many would consider that that is where the responsibility for on-going operation and maintenance should lie. Unfortunately in the Haitian context (as indeed in most of the developing world) local government is unable to take on this role. It does not have the human, physical or financial resources to take on this task and so it would be unwise to ask them.

#### **10.6 Hand community toilets to the users**

One of the big advantages of providing community toilets is the direct relationship between the structure and the user. In theory, once users have accepted ownership of their particular cubicle then they should also accept responsibility for its maintenance. Unfortunately the practice rarely lives up to the theory. Inter family arguments about toilet access and cleaning, responsibility for repairs and payments for emptying are common. The bigger the number of families using each cubicle or sharing a common waste storage tank, the greater the likelihood of inter family conflict.

Again there is a need to provide the mentoring and support of an intermediary. A local NGO skilled in working with communities should be able to take on this role but there will be financial implications.

## 11. References

- SPHERE (2004) *Humanitarian Charter and Minimum Standards in Disaster Response*.  
[www.sphereproject.org](http://www.sphereproject.org)
- Jones. H., Reed. B. (2005) '*Water Supply for Disabled People and Other Vulnerable Groups*'.  
WEDC, Loughborough University, UK <http://wedc.lboro.ac.uk/>
- Harvey P. A (2007) '*Excreta Disposal in Emergencies: A field manual*'. WEDC,  
Loughborough University, UK. <http://wedc.lboro.ac.uk/>
- Obika A. (2004) '*Catalogue of Low Cost Toilet Options*'. WEDC, Loughborough University,  
UK. <http://wedc.lboro.ac.uk/>
- Reed R, Shaw R (2008) '*Sanitation for primary schools in Africa*'. WEDC, Loughborough  
University, UK. <http://wedc.lboro.ac.uk/>

## 12. Technical drawings

### 12.1 IFRC Four cubicle over 500 gallon storage tank

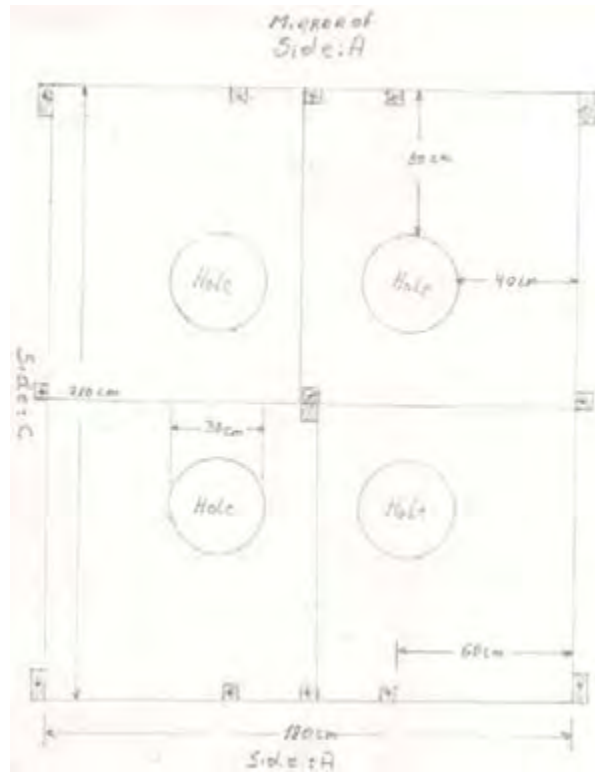
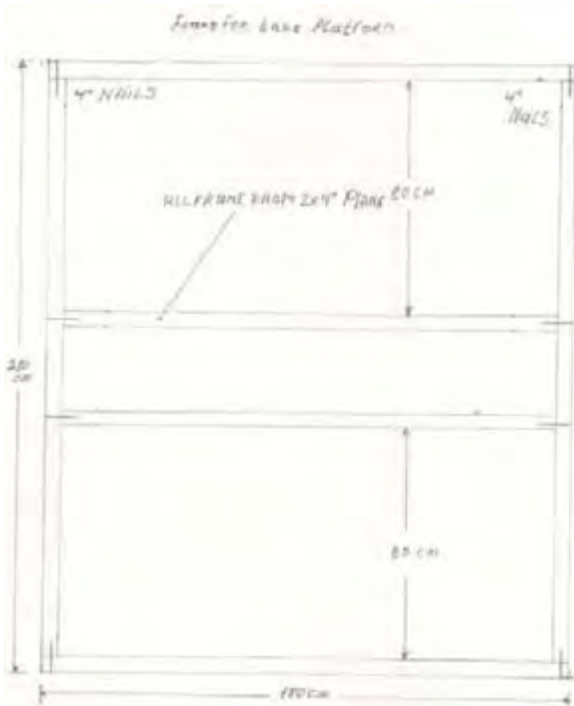



EMERGENCY EXCRETA DISPOSAL STANDARDS AND OPTIONS FOR HAITI

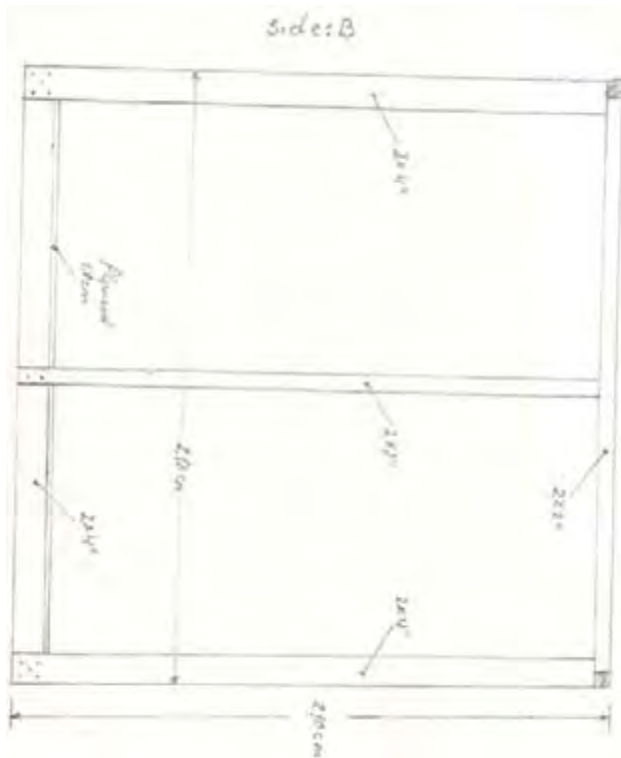
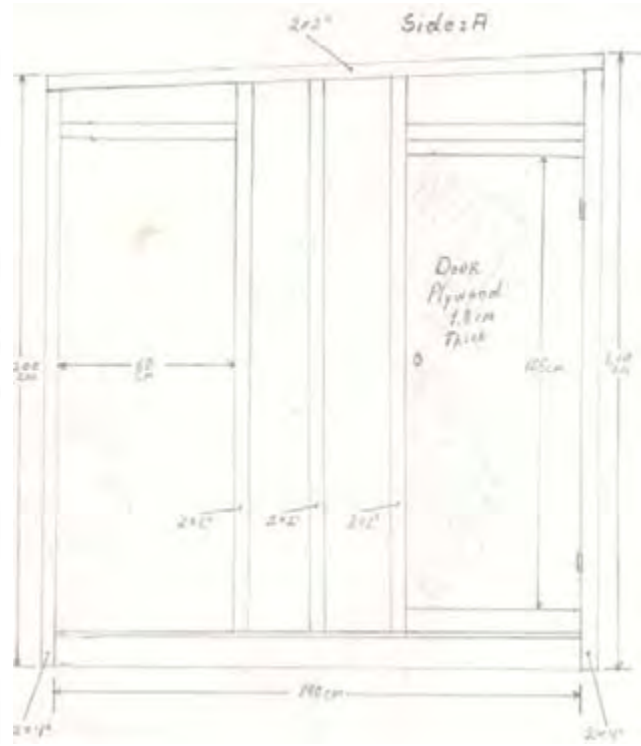
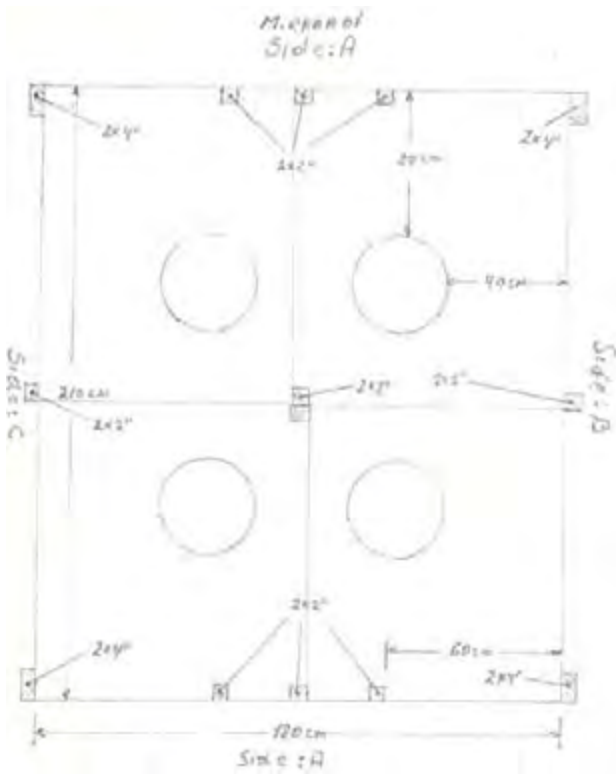

## 12.2 UNICEF three compartment trench toilet

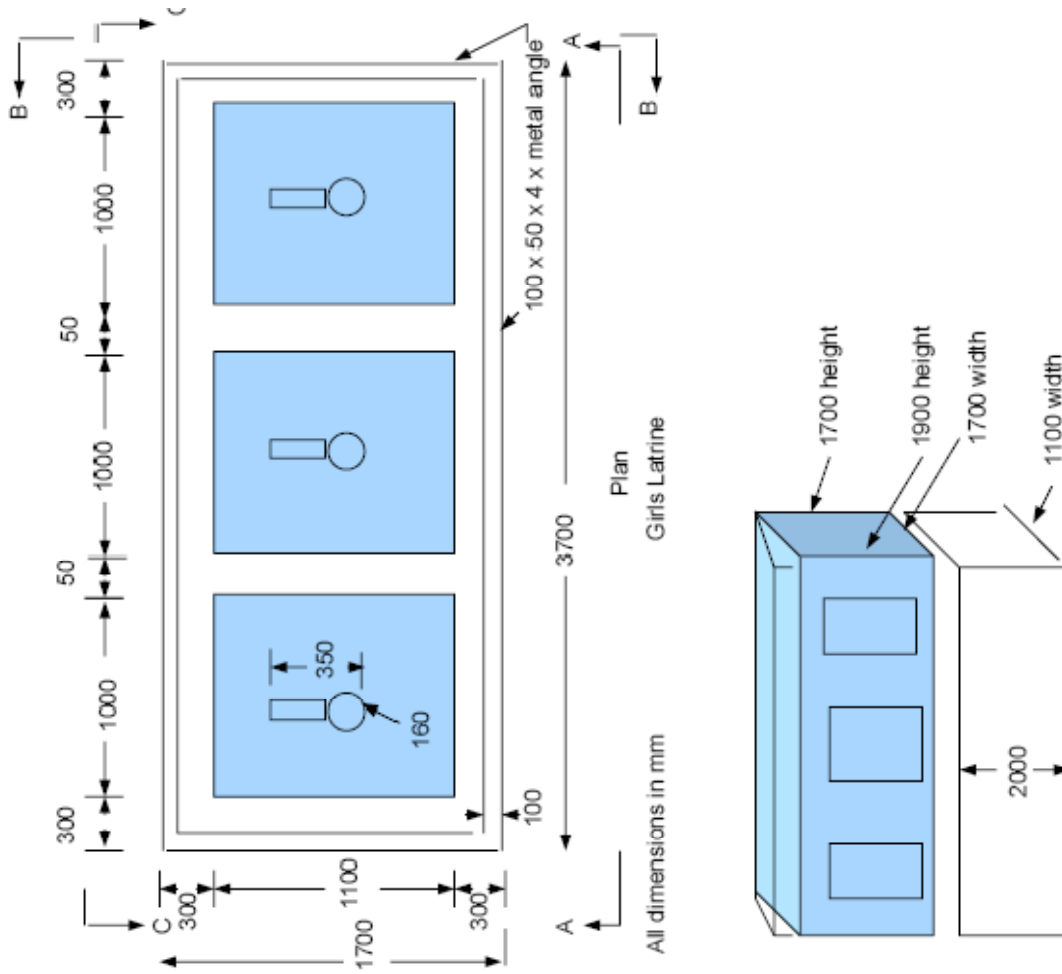

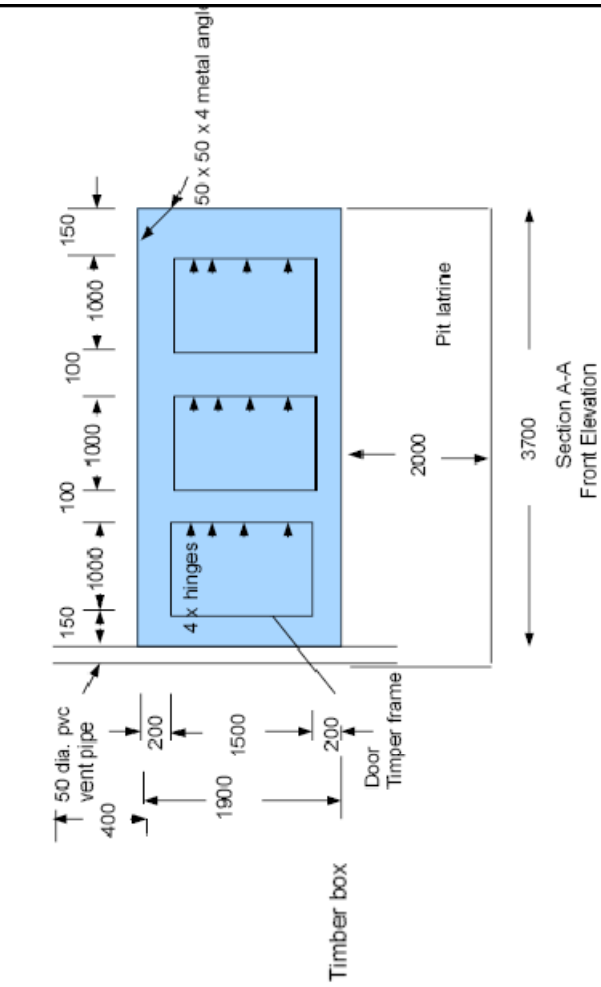

Notes: bolts and metal plate are to be provided at required at joints

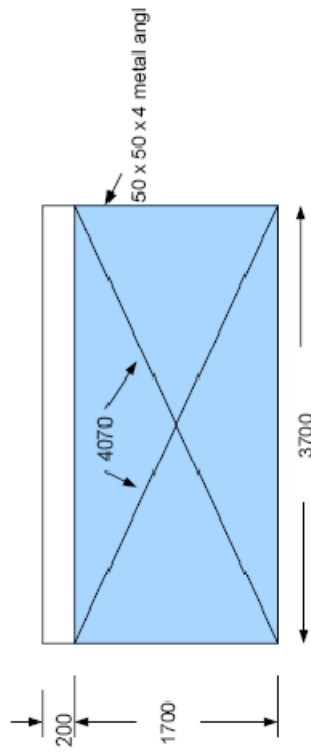

all dimensions are in millimeters

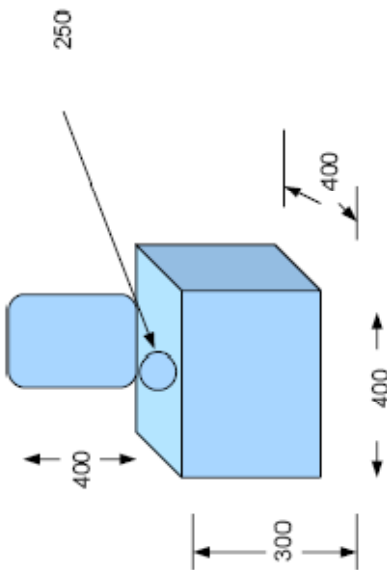

### 12.3 Oxfam emergency latrine

Oxfam GB

Haiti Earthquake Response 2010

Emergency Pit Latrines - construction sequence.

- 5 x latrine slabs
- 4 x 1" x 8" x 14' timber planks
- 6 x 2" x 2" x 16' posts (cut in half)
- plastic sheeting
- 1" nails
- 3" nails

8 pages total  
drawn by Step. 2.

① Dig pit : 3.8m x 0.9m x ~2m deep

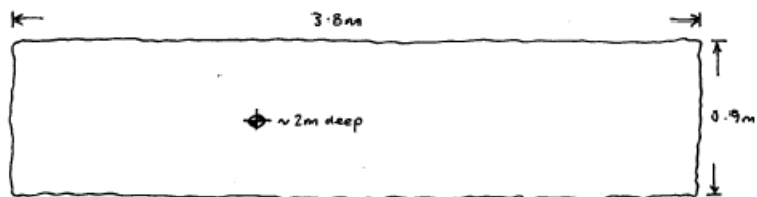

Plan ~ 1:20

- ② Cut two long planks into thirds.  
Fix 8" x 8" square of plank to centre of each short plank with 1" nails.  
Lay short planks across pit and at short edges.

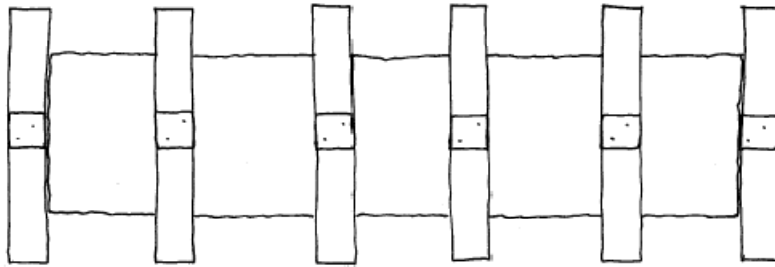

- ③ Add long planks to long edges of pit. Fix to short planks with 1" nails.

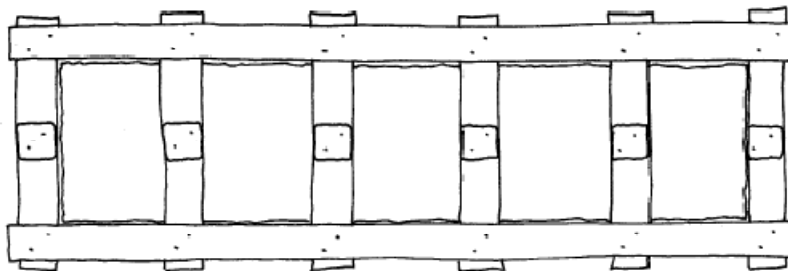

- ④ Carefully position plastic latrine slabs; alternate direction.  
Fix in position with 3 or 4 3" nails in each corner.

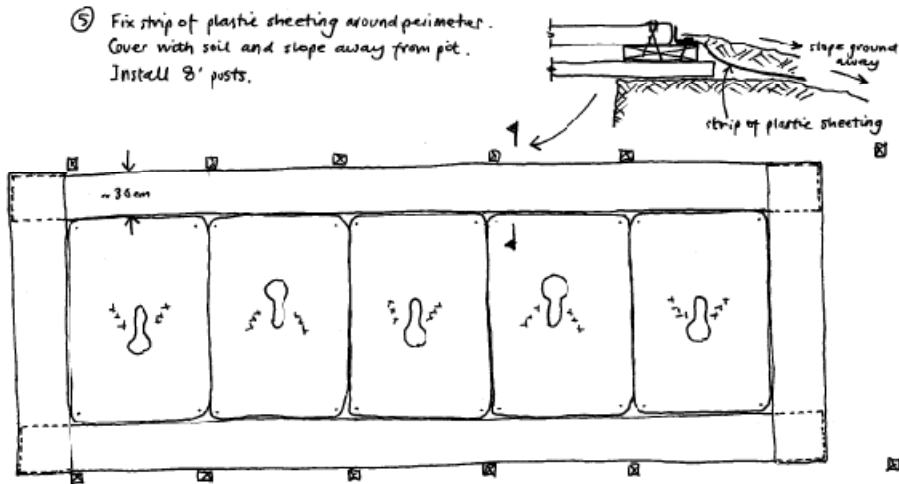
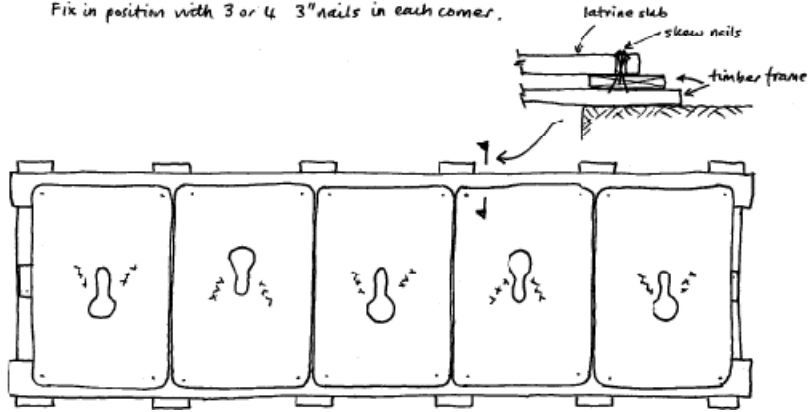

- ⑥ Add single length of plastic sheeting.  
 Fix to posts with 1" nails through a  
 folded square of plastic sheeting (as washer)

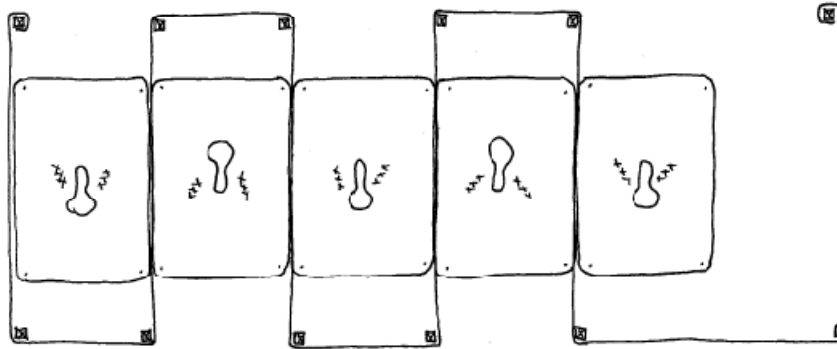
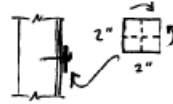

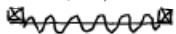
- ⑦ Add doors. Add short post to hold on to in larger and latrine.  
 (Doors could be sheets of plastic weighed down with strips of wood or  
 concertina plastic sheeting fixed through wire : ).

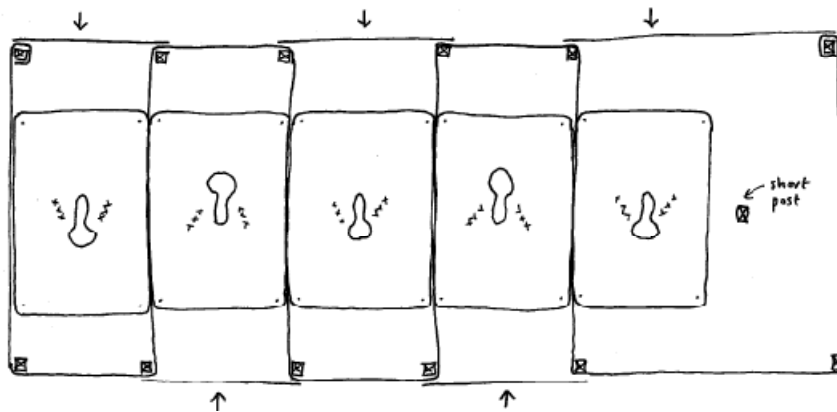

### 12.4 ARI Temporary school latrine block

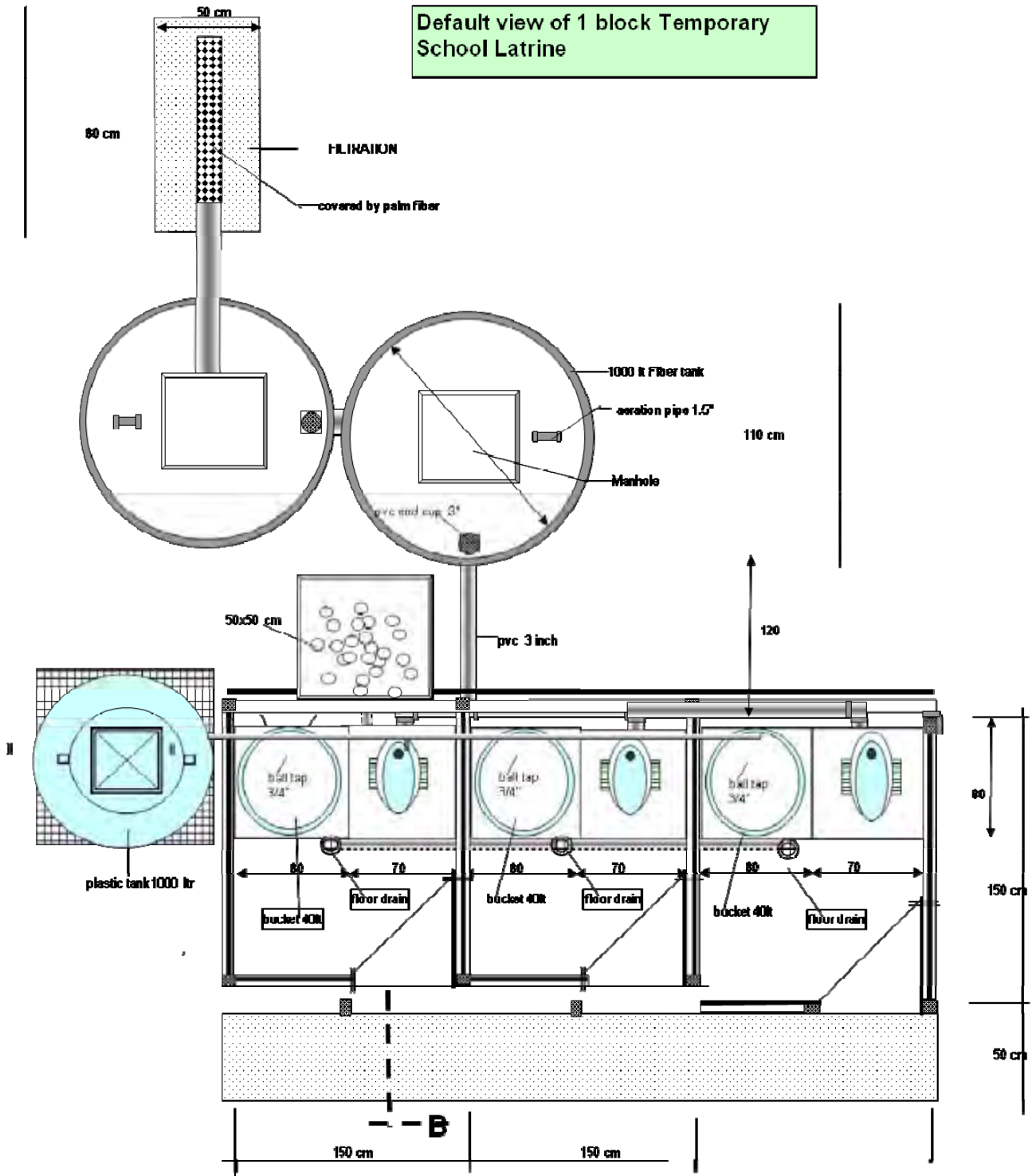



Front View

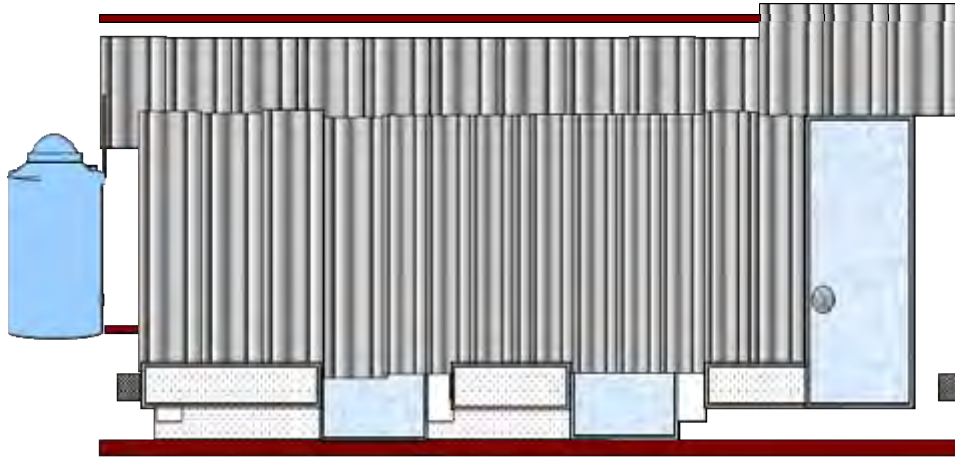

Side View

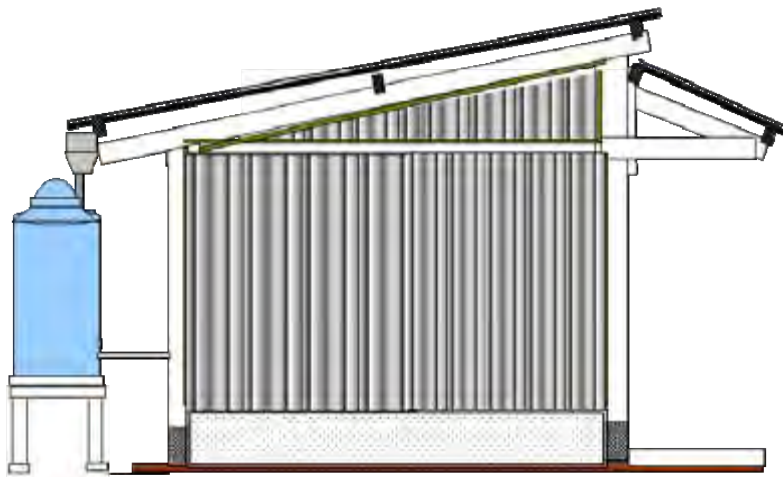

Section A

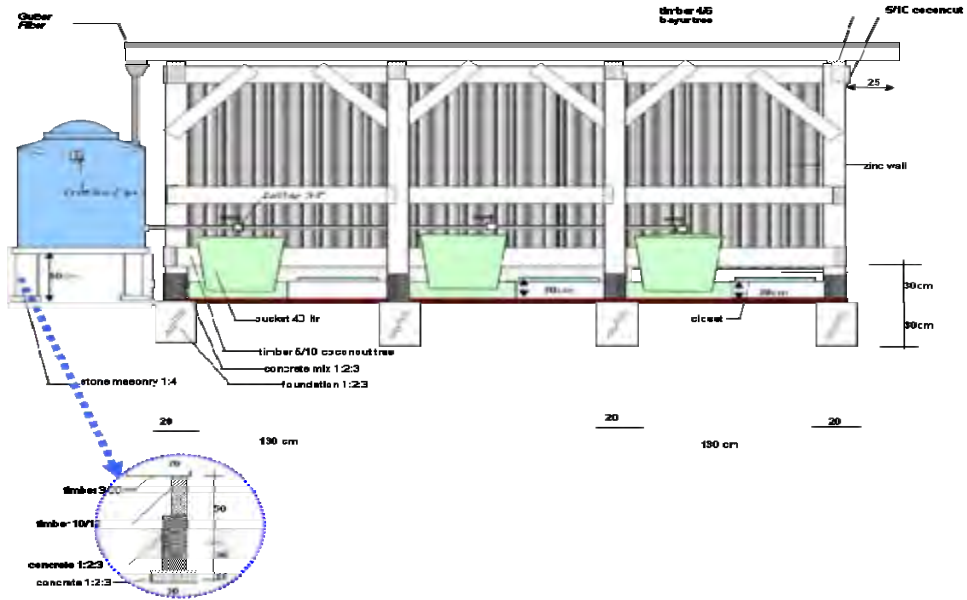

Section B

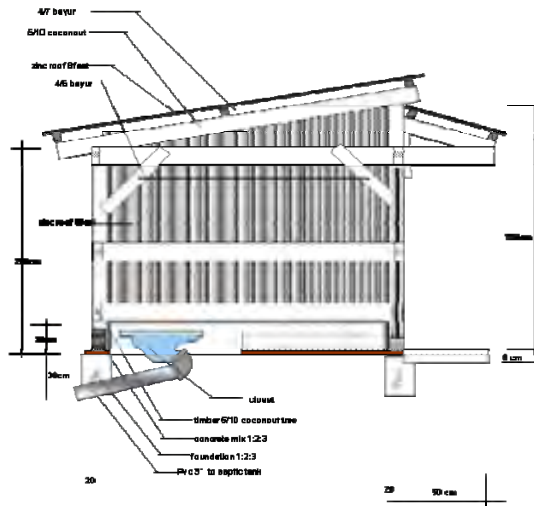

septic tank fiber tank + filtration

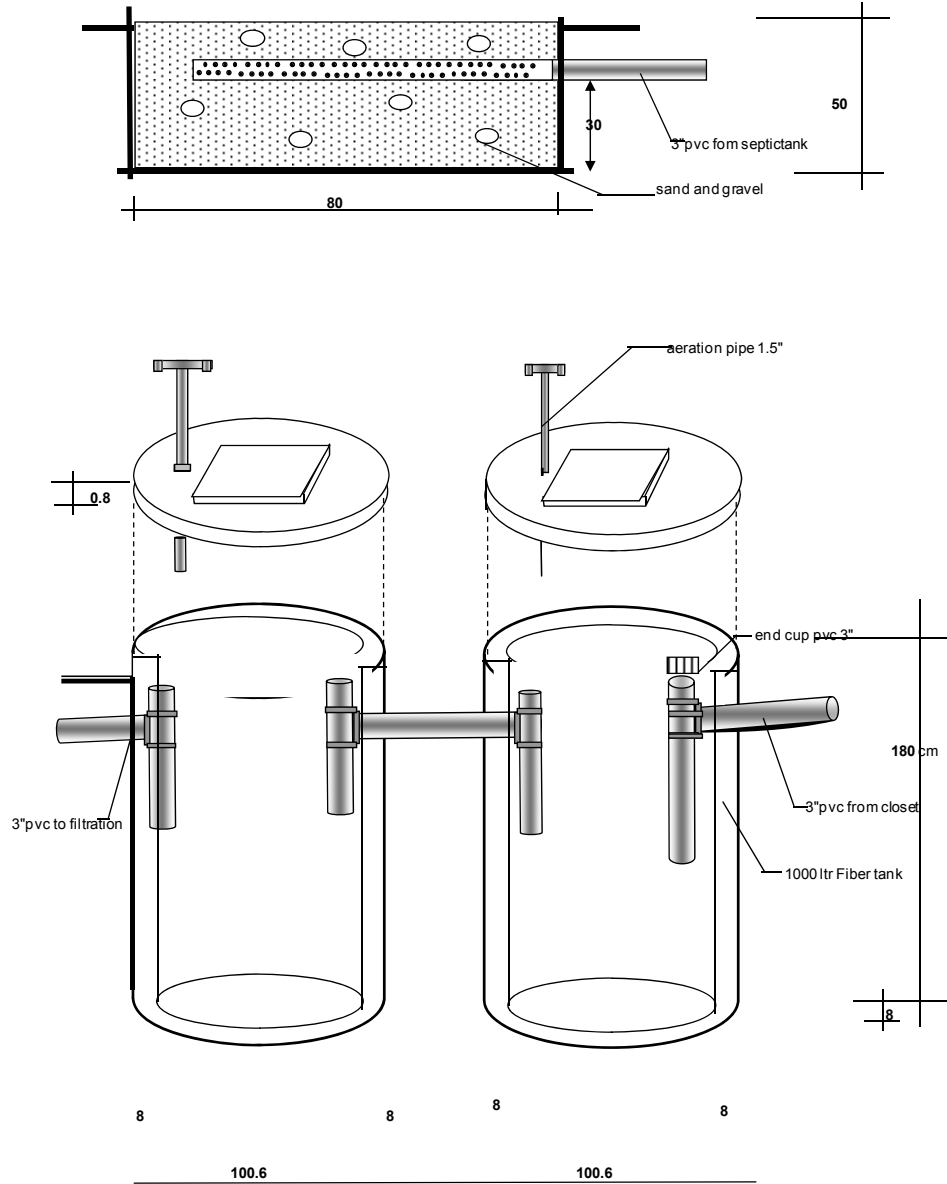

## 12.5 Construction details for a GOAL trench toilet



## 12.6 Aprosifa two compartment pit toilet

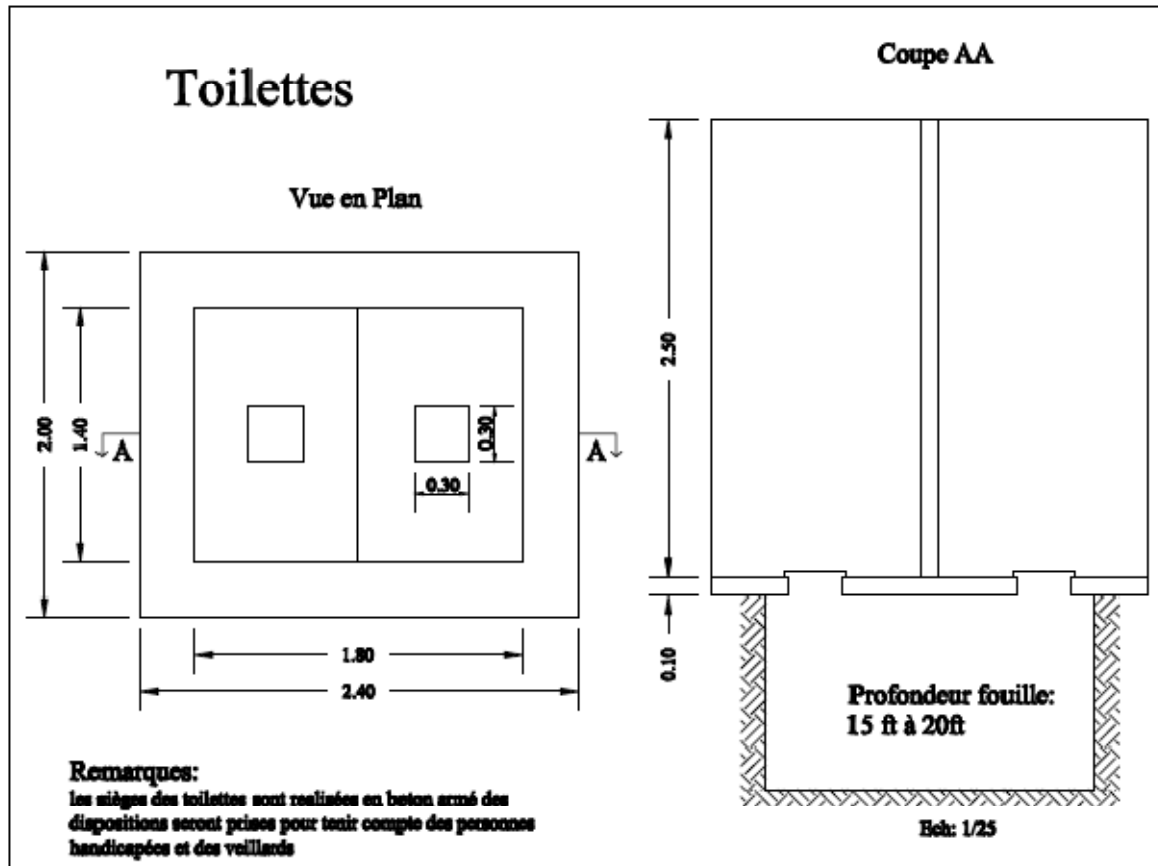

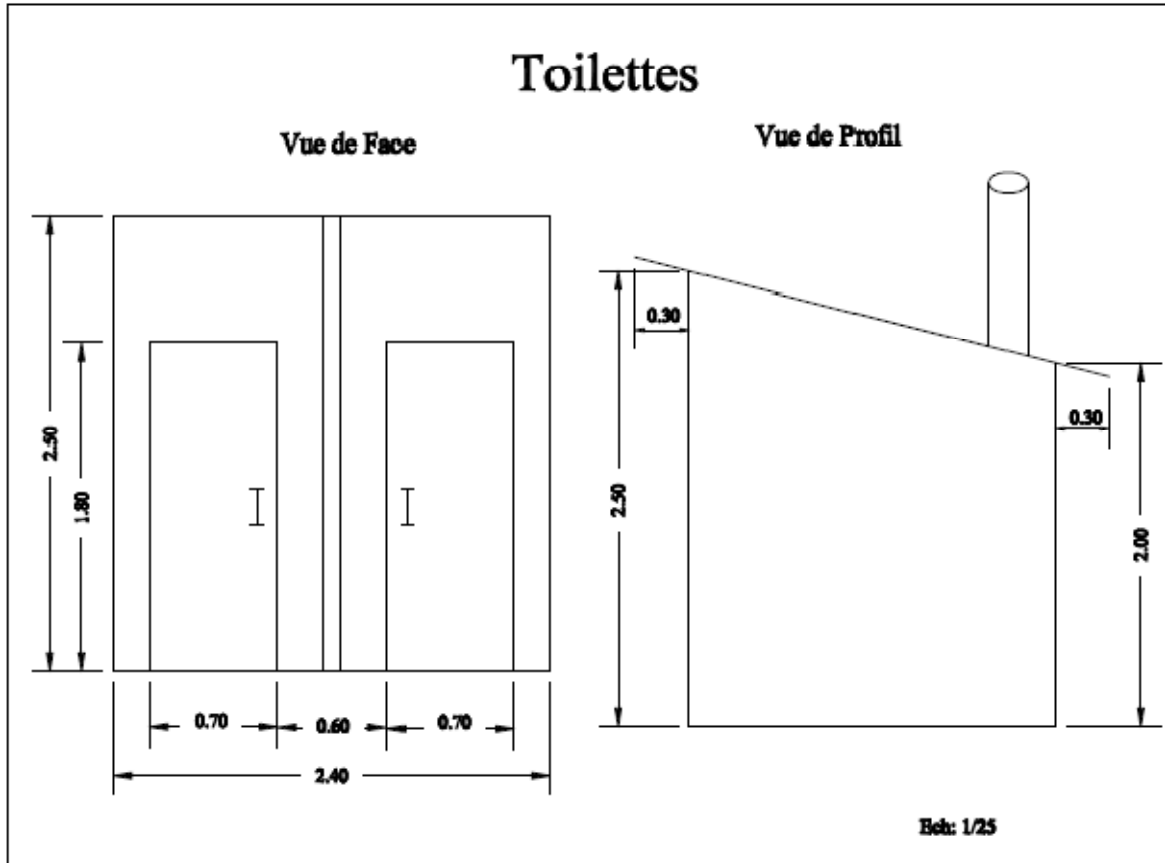

## 12.7 Timber support systems for trenches in unstable ground

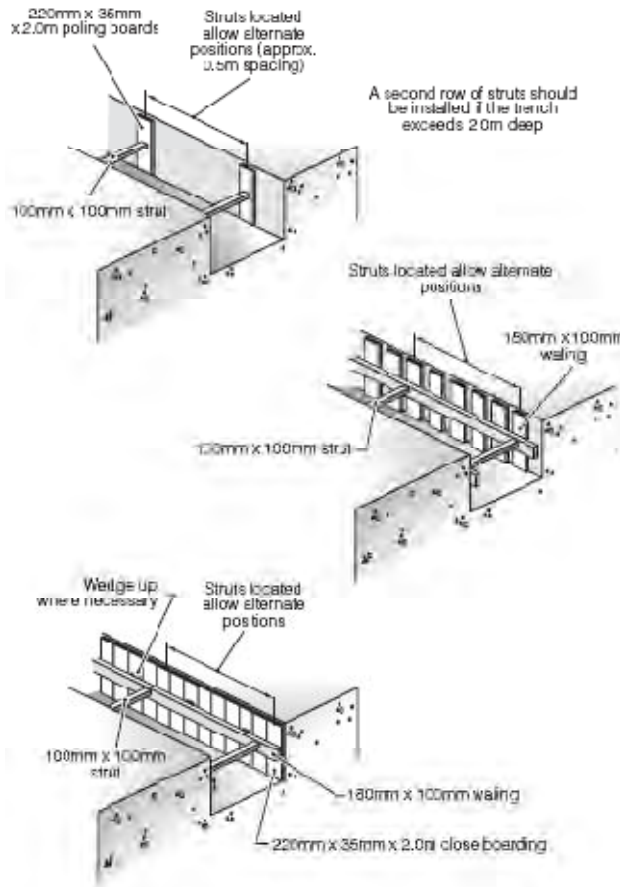

(Harvey 2007)

## 12.8 Pit lined with sand bags

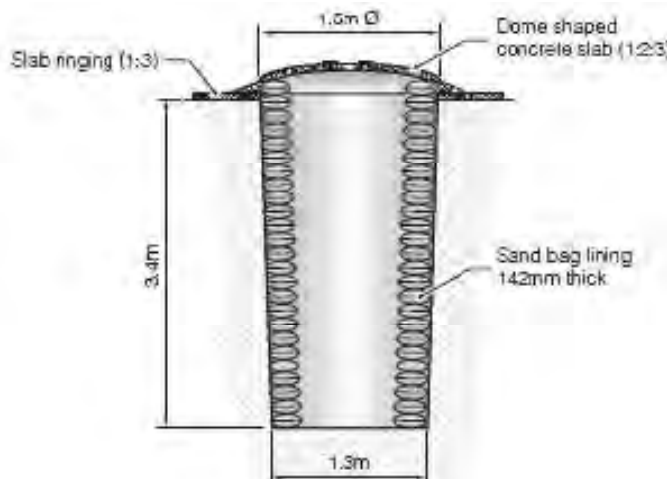

(Harvey 2007)

### 12.9 Reinforced concrete toilet squatting slab

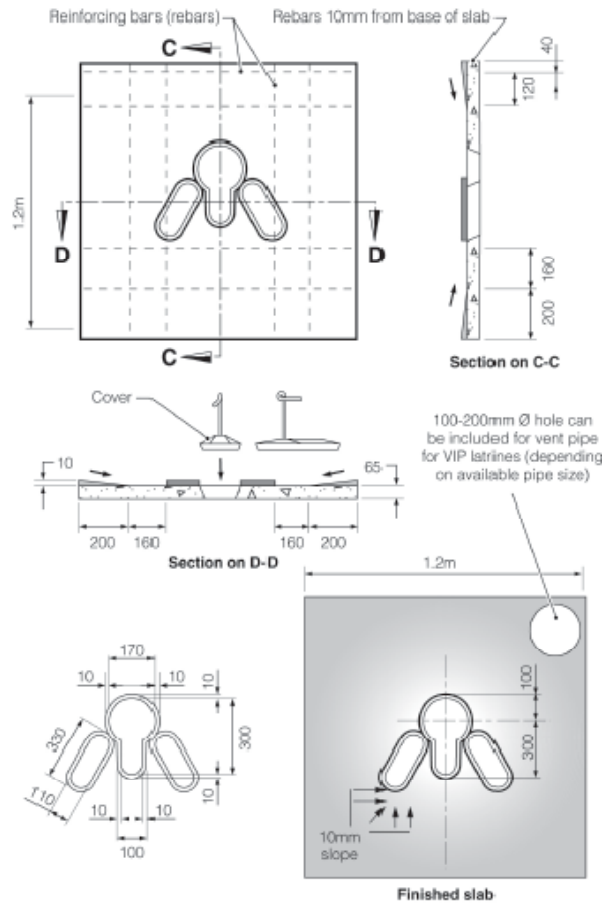

(Harvey 2007)

### 12.10 Unreinforced domed squatting slab

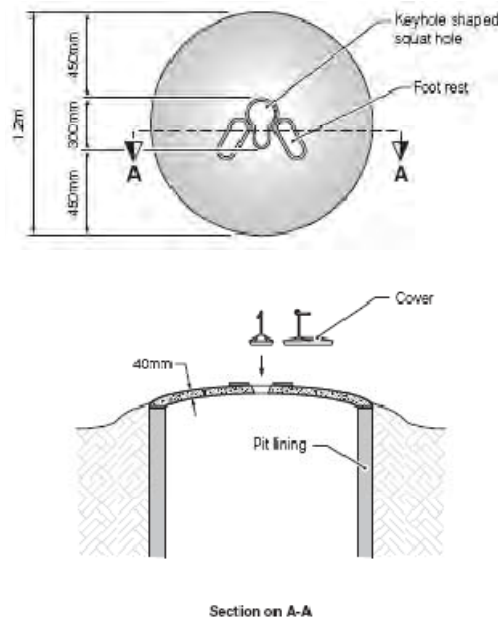

(Harvey 2007)



### 12.11 Timber frame for trench toilet

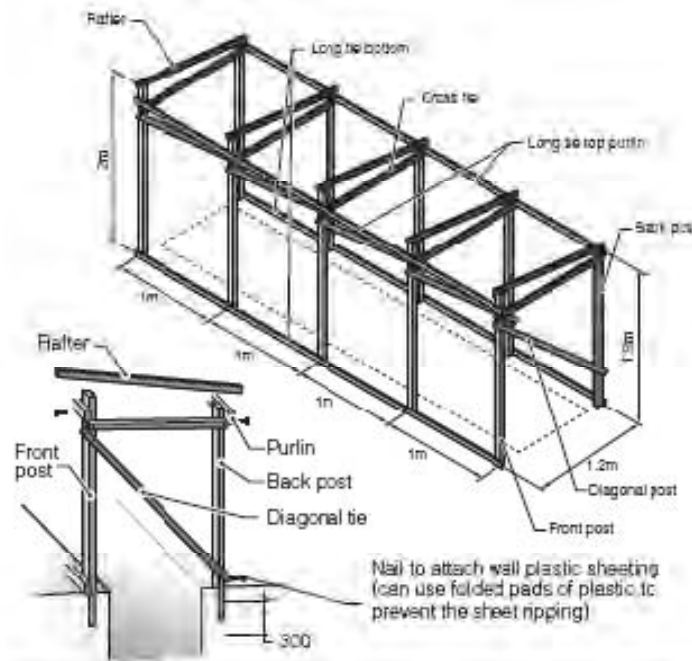

Frame		Quantity	
1	Front post	50 x 50 x 2000mm	5
2	Back post	50 x 50 x 1800mm	5
3	Cross tie	25 x 50 x 1200mm	5
4	Diagonal tie	25 x 50 x 1800mm	5
5	Long tie bottom	25 x 75 x 3700mm	2
6	Long tie top	25 x 75 x 4400mm	2
7	Vitali (plastic sheet)	(3700 + 1300) x 2 x 1650	16.5m <sup>2</sup>
8	2" (50mm) wienail	10 x 5	50
9	1" (25mm) bottom pin for wall fixing	250gms	
Roof			
1	Rafter	38 x 50 x 2000mm	5
2	Purlin	25 x 50 x 4400mm	3
3	Roof cover	2000 x 4400mm	8.8m <sup>2</sup>
4	2" tin screw		30

Note: Actual dimensions will depend on available timber styles.  
Dimensions indicated are suggested minimum values.

(Harvey 2007)

## 12.12 Toilet cubicle frame made of uPVC pipe

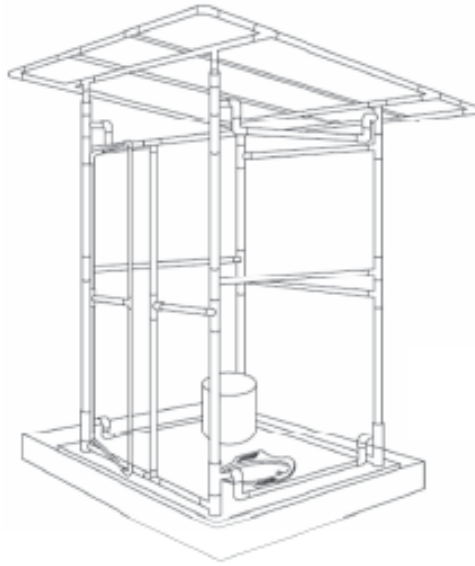

(Harvey 2007)

### 12.13 Layout of a women's toilet and washroom area

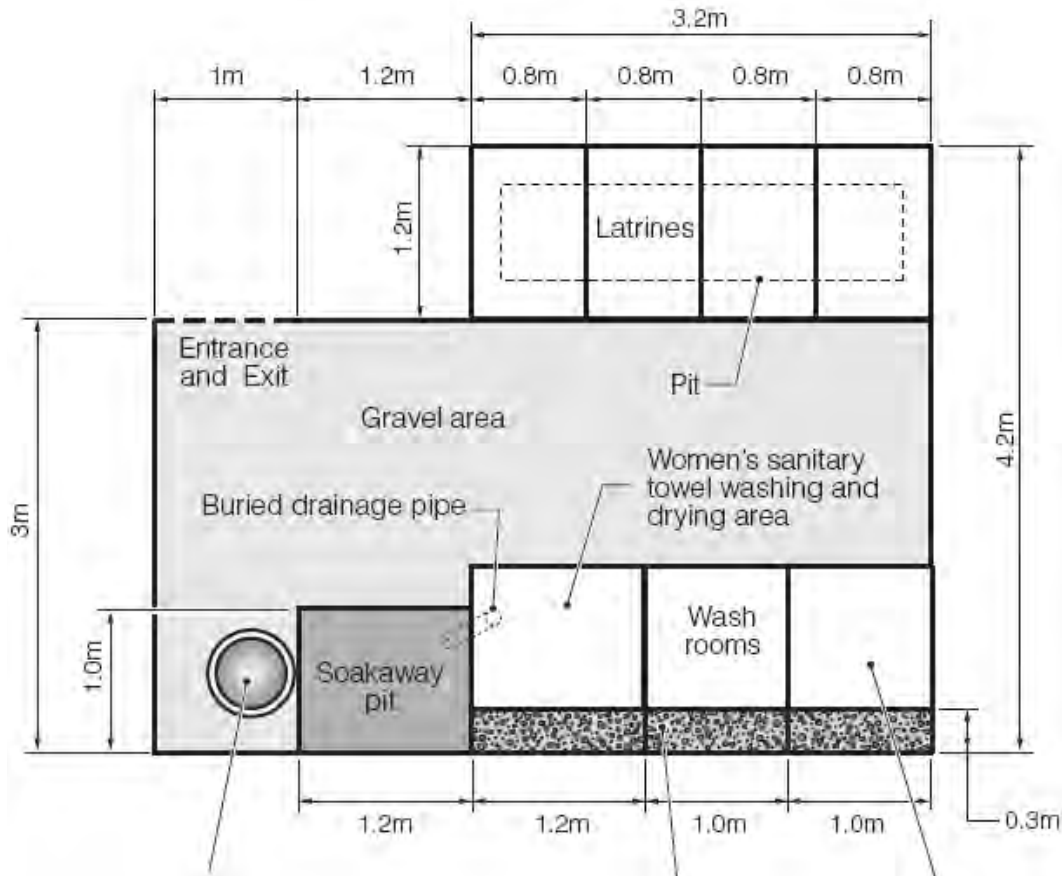

Hand-washing barrel with tap and soap broken into pieces to try and prevent it being stolen, and hung in a sock or small sack tied to the hand washing barrel).

The barrel should ideally be standing on the soak-pit and near to the exit door of the screened areas (as a reminder for people to wash their hands).

Stone filled drainage channel which should be within the wash room units and under the covered roof area.

Sloping concrete or marble slabs placed on a bed of sand, with smooth finish for easy cleaning.

(Harvey 2007)

### 12.14 Designs for hand washing areas

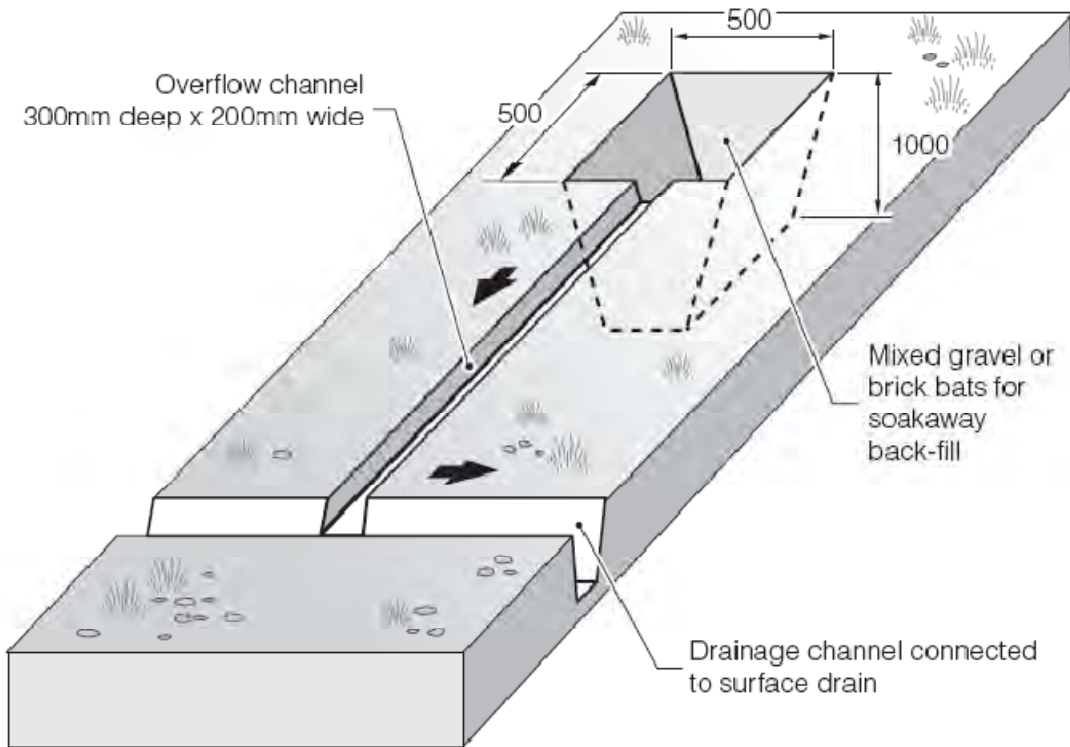
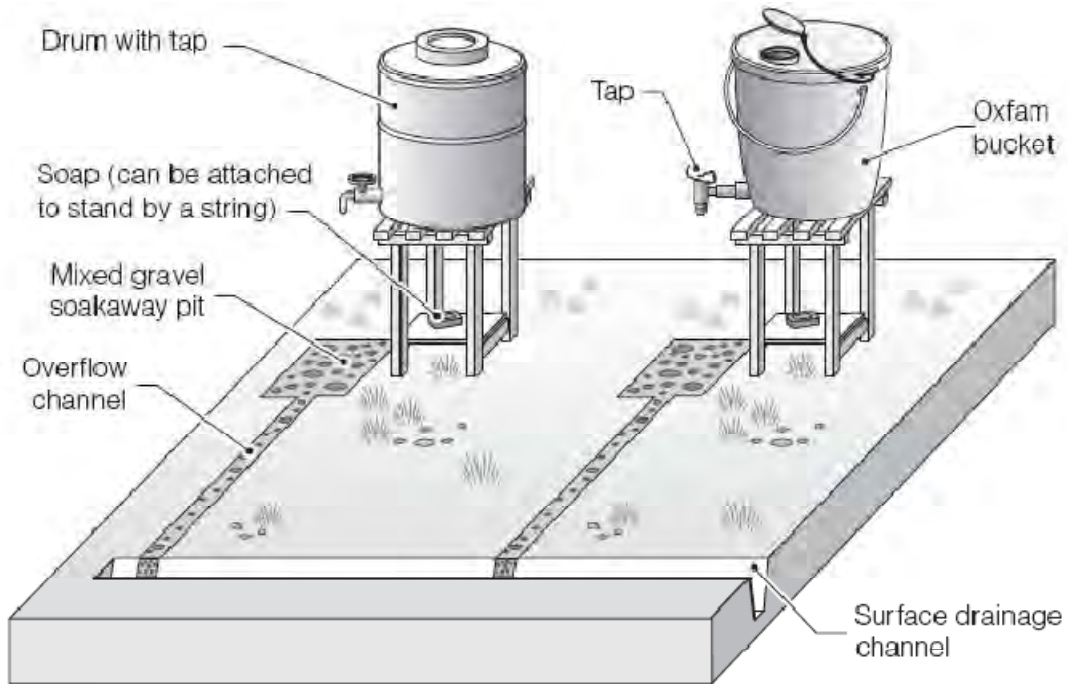

**Soakaway detail**

(Harvey 2007)

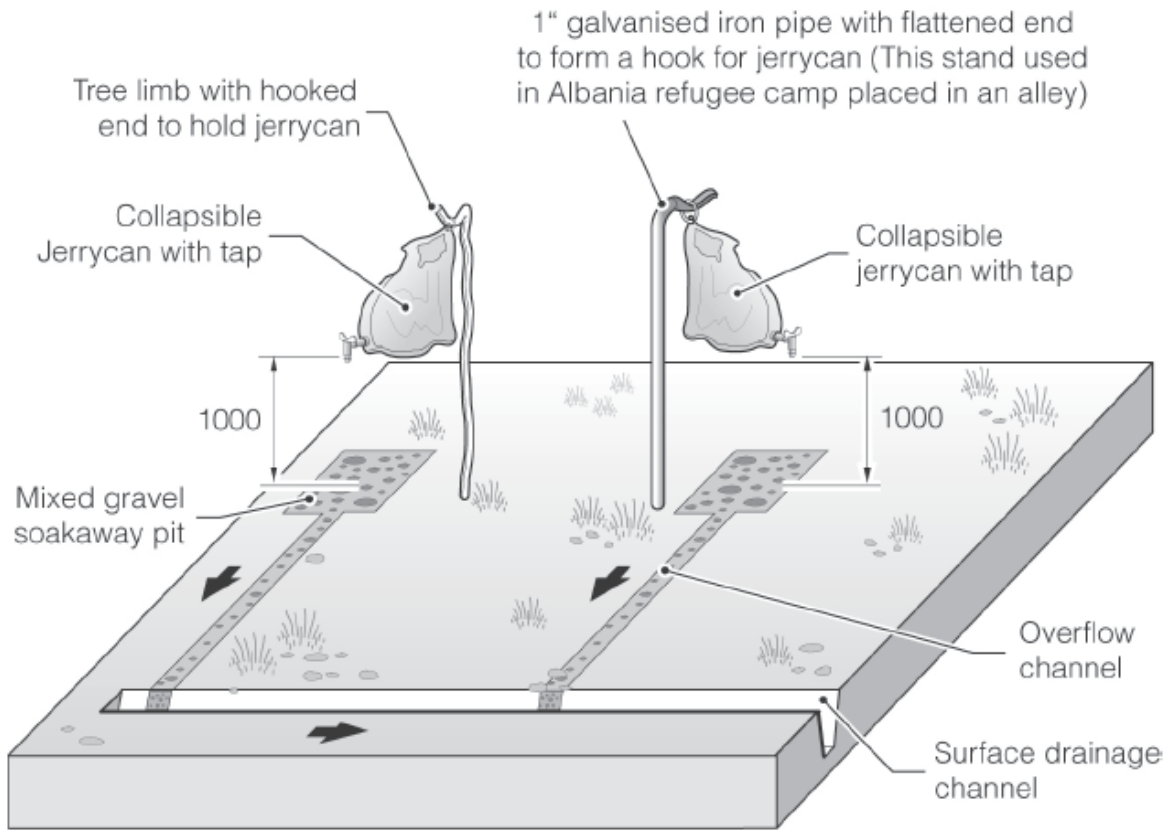

**Jerrycan hanger**  
(Harvey 2007)



**The Tippy Tap**



**The Handy Andy**



**The Captap - Stage 1**



**The Captap - Stage 2**

(Harvey 2007)

### 12.15 Design and BoQ for trench latrine

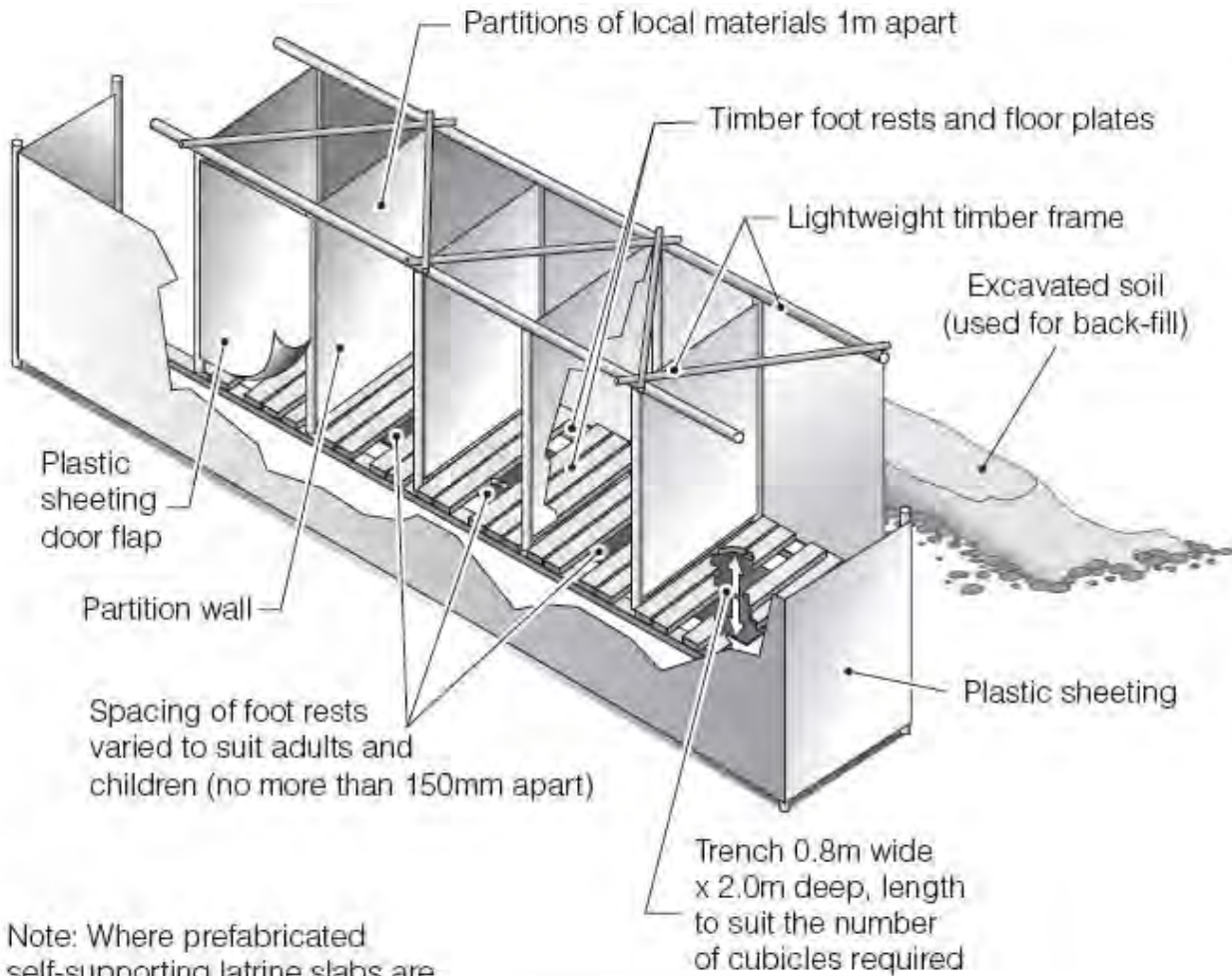

Note: Where prefabricated self-supporting latrine slabs are to be used in place of timber cubicle sizes may need to be adjusted to fit slab width (e.g. 0.8m)

#### Superstructure

EMERGENCY EXCRETA DISPOSAL STANDARDS AND OPTIONS FOR HAITI

Dimensions	Length (m)	Width (m)	Depth (m)
Excavation of trench	4.00	0.80	2.00
Superstructure	Unit	Quantity	Linear metric length (m)
Timber 50 x 50 x 2300mm RT	front post	5	11.50
Timber 50 x 50 x 2100mm RT	back post	5	10.50
Timber: 50 x 25 x 1200mm RT	cross tie	5	6.00
Timber: 50 x 25 x 1800mm RT	diagonal tie	5	9.00
Timber: 75 x 25 x 4000mm RT	long tie (bottom)	2	8.00
Timber: 75 x 25 x 4000mm RT	long tie (top)	2	8.00
Galvanized-wood nails 2"	No.	40	
Galvanized-wood nails 1"	No.	186	
Bottle tops or folded plastic pads	No.	226	
Plastic sheeting (2m wide x 1m long)	walls	10	10.00
Plastic sheeting (2m wide x 1m long)	door	4	4.00
Slab and supports			
Timber: 15 x 100 x 4000mm RT	support planks	2	8.00
Wooden Slab: 1m x 1.2m	slab	4	
Roof			
Timber: 38 x 50 x 1800mm RT	rafter	5	9.00
Timber: 25 x 25 x (4000+400) mm RT	purlin	3	13.20
Plastic sheeting (2m wide x 1m long)	roof	4.8	4.80
Bottle tops or folded plastic pads	No.	86	
Galvanized-wood nails 1"	No.	86	
Privacy screen (optional)			
Timber 50 x 50 x 2300mm RT	posts	5	11.50
Plastic sheeting (2m wide x 1m long)	screen	8	8.00
Bottle tops or folded plastic pads	No.	52	
Galvanized-wood nails 1"	No.	52	

(Harvey 2007)



### 12.16 Design and BoQ for single cubicle

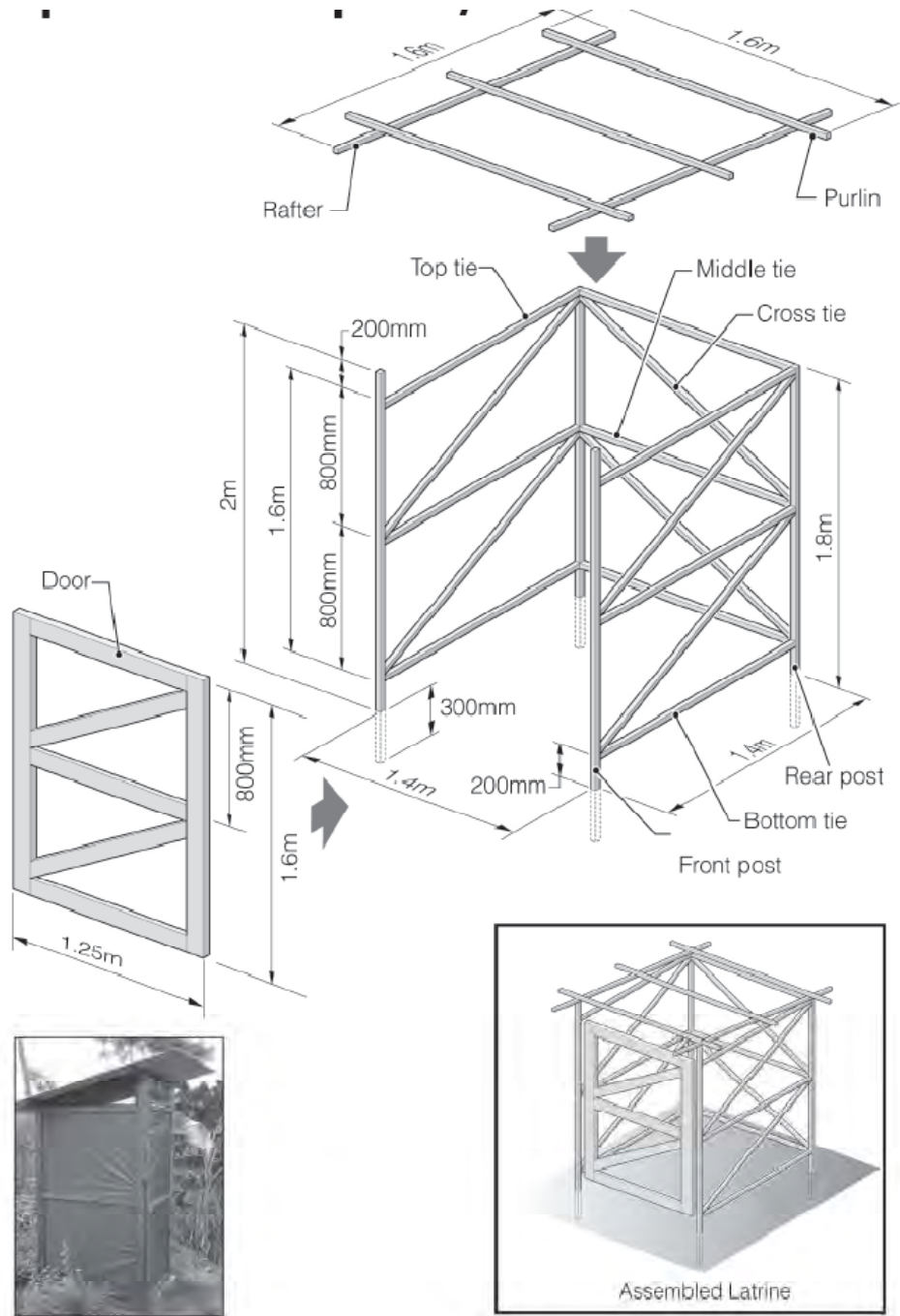

(Harvey 2007)

EMERGENCY EXCRETA DISPOSAL STANDARDS AND OPTIONS FOR HAITI

Dimensions	Depth (m)	Diameter (m)	
Excavation of pit	3.00	0.80	
Superstructure frame	Unit	Quantity	Linear metric length (m)
Timber: 50 x 50 x 2300mm RT	front post	2	4.60
Timber: 50 x 50 x 2100mm RT	back post	2	4.20
Timber: 38 x 25 x 1750mm RT	cross tie	6	10.50
Timber: 50 x 50 x 1300mm RT	bottom tie	3	3.90
Timber: 38 x 50 x 1300mm RT	middle tie	3	3.90
Timber: 50 x 50 x 1300mm RT	top tie	3	3.90
Galvanized-wood nails 2"	No.	30	
Door frame			
Timber: 38 x 50 x 1600mm RT	uprights	2	3.20
Timber: 38 x 50 x 1400mm RT	cross tie	2	2.80
Timber: 38 x 50 x 1150mm RT	horizontal ties	3	3.45
Hinges	No.	3	
Wood screws (1.5")	No.	18	
Galvanized-wood nails 2"	No.	10	
Roof			
Timber: 38 x 50 x 2000mm RT	rafter	2	4.00
Timber: 25 x 25 x 1800mm RT	purlin	3	5.40
Corrugated-iron sheeting (2m x 1.8m wide)	roof	1	
Galvanized-roofing nails	No.	8	
Slab			
Domed-concrete slab (1.2m diameter) OR Reinforced-concrete slab: 1m x 1.2m OR Self-supporting plastic (Oxlam) slab: 0.8m x 1.2m	slab	1	
Superstructure: CORRUGATED IRON			
Corrugated-iron sheeting (1.6m x 1.4m wide)	walls	3	
Corrugated-iron sheeting (1.6m x 1.2m wide)	door	1	
Galvanized-roofing nails	No.	36	
Superstructure: WOODEN SLATS			
Timber: 75 x 15 x 1400 mm RT	walls	66	92.40
Timber: 75 x 15 x 1250 mm RT	door	22	27.50
Galvanised wood nails 1.5"	No.	176	
Superstructure: PLASTIC SHEETING			
Plastic sheeting (2m wide x 1 m long)	walls	4.2	4.20
Plastic sheeting (2m wide x 1 m long)	door	1.3	1.30
Bottle tops or folded plastic pads	No.	88	
Galvanized-wood nails 1"	No.	88	

(Harvey 2007)

