

Rehabilitating water treatment works

TECHNICAL NOTES ON DRINKING-WATER,
SANITATION & HYGIENE IN EMERGENCIES

Originally designed for print, this is one of the series of highly illustrated notes prepared by WEDC for WHO to assist those working immediately or shortly after an emergency to plan appropriate responses to the urgent and medium-term water, sanitation and hygiene needs of affected populations.



TN 6



**World Health
Organization**



**Loughborough
University**

Contents

Introduction	3
Steps for rehabilitation	3
Assess the situation	4
Decide what to do first	7
Pumps and power	10
Works operation	11
Public information.....	13
Overview of a water treatment system	13
Further reading	23
About this note	24

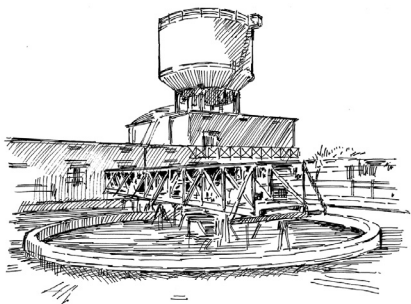

Introduction

In urban areas, the populations be entirely reliant on public water supply systems for drinking-water. Modern water treatment works rely on the inputs of skilled operators as well as supplies of chemicals, electricity and machinery.

A disaster can cause extensive damage to the works leading to a reduced or even a total loss of output. This technical note identifies the first steps to take towards rehabilitating a water treatment works after an emergency. Details of the rehabilitation of smaller systems are given in Technical Note 4 ([mobile note 34](#)).

Steps for rehabilitation

In an emergency, the primary goal of rehabilitating a water treatment works is to maximize the quantity of water produced. This is followed by the gradual, step-by-step improvement in

water quality. Most water treatment works are connected to a piped distribution system. This, too, needs to be rehabilitated if the treated water is to reach the consumer. Details of the rehabilitation of distribution systems are given in Technical Note 4 ([mobile note 34](#)).

Assess the situation

Identify key workers

Identify local water treatment operators who understand the system. They can provide knowledge of the works and the sources of supply.

Often, however, operators do not fully understand the treatment process, so try to identify professional engineers, scientists and managers who do.

Note that you may have to pay operators and managers if the emergency has interrupted their salary payments.

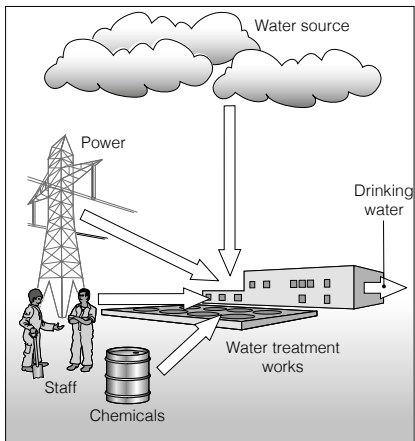

Figure 1. Modern water treatment works rely on the inputs of skilled operators as well as supplies of chemicals, electricity and machinery that functions reliably

Understand the process

In order to rehabilitate the water treatment plant it is important to understand how it works. Individual

plants will vary in design, but most are based on a sequence of processes that fit together to improve the quality of water in incremental steps. Figures 4-8 pictured towards the end of this note show the principal processes. Not all processes shown will operate in every case. In some cases the order in which they take place will differ.

Assess the condition of the plant

The condition of each plant component will need to be assessed. Identify which components are working, which could be repaired and which will have to be replaced.

Repair and renovation is generally quicker than replacement, particularly if skilled workers are available locally.

Be aware that damaged components may not necessarily be related to the disaster. Chronic underfunding and lack of skilled workers is a common problem

in the water industry, so treatment plants frequently do not function correctly, not only during emergencies.

Decide what to do first

The first requirement is to get water into the distribution system quickly. Water quantity (rather than quality) provides the main health and social benefits during an emergency. Treatment, therefore, can be limited in the first instance, but ensure that the water is free of gross contaminants that may block or damage pipes and pumps.

Preventing pollution

The first step in improving water quality is to reduce the need for treatment by minimizing the level of pollution at source. Providing environmental sanitation services (such as the management and disposal of excreta, solid waste and rainwater), controlling erosion, reducing agricultural pollution and restricting direct public access to the

water source can reduce the amount of contaminants that have to be removed from the water (Figure 6.2). In many cases, restoring a sewage collection and treatment system may be a greater priority than completely rehabilitating the water treatment works.

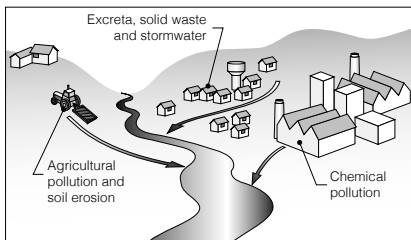
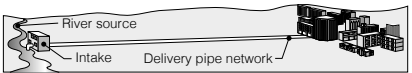

Figure 2. Preventing pollution upstream as shown will reduce the need for treatment

Staged rehabilitation

The priority for treatment works rehabilitation is shown in Figure 6.3 below.



Water intake and delivery pipe network

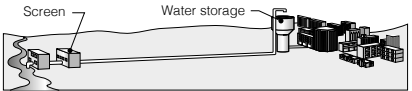

Primary screening

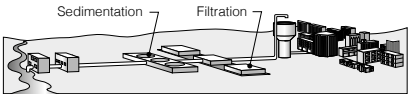

Sedimentation and filtration

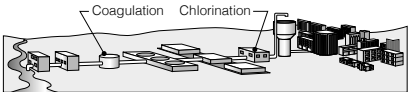

Coagulation and chlorination

Figure 3. Water treatment in stages

If the water is relatively clear, chlorination can be introduced at an earlier stage. This may involve the

installation of temporary pipelines to by-pass damaged sections of the plant. If major components of the works such as storage reservoirs and sedimentation tanks are badly damaged, their repair or replacement will be expensive and take a long time. During the emergency phase they should be replaced with temporary equipment such as portable storage tanks.

Pumps and power

Pumps (and the motors that drive them) are essential components of many treatment works. They have a variety of uses such as raising water from the intake into the works, between different elements in the works, or for adding and mixing chemicals. It will be essential to the overall operation of the works that they function well, so their rehabilitation must be a priority. Replacement parts may take time to be delivered, so ask an engineer to make an early assessment of the state of the pumps.

Power is also essential and an additional priority. If the mains supply is not working, install mobile generators.

Works operation

As soon as components of the treatment works have been re-commissioned, their operation will need to be sustained. This will include:

- **Monitoring:** The quality and quantity of water being produced by the works should be measured regularly to check whether everything is working correctly and that the output meets minimum standards (see the Sphere Guidelines for minimum standards for emergency water supplies).

Simple test kits are available for measuring basic parameters of water quality.

Sources of further information are given at the end of this note.

- **Chemicals:** Modern treatment works rely on the addition of chemicals to aid the treatment process. These include alum to help settlement, lime for adjusting the pH of the water and chlorine for disinfection.

It may take a long time to replenish supplies so the need for chemicals should be identified and suppliers contacted as soon as possible.

A reduced level of treatment can be provided if chemicals are in short supply, using point of use disinfection where it is most needed, such as in hospitals and schools.

- **Maintenance:** This includes manual tasks, such as cleaning screens, removing settled sludge and lubricating pumps. The filters will become clogged with solids. Pipes will need to be checked for leaks.

Public information

The public should be kept informed of developments. This will ease concerns about water availability and help to reduce wastage, particularly if the public can help identify leaks in the distribution system.

Overview of a water treatment system

Source: Water may be taken from surface water or groundwater. Prevent pollution to reduce the amount of treatment needed later.

Intake: Some simple treatment may take place at the intake, such as a coarse screen or aeration.

Storage at this stage allows some solids to settle out before treatment and provides a limited reservoir of water if the source fails (e.g. an oil spill in a river).

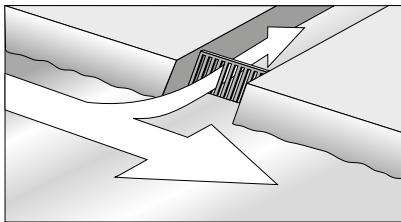

Figure 4. Intake

Settlement/clarification: If the water is stored for a while, solids will fall to the bottom of the tank and scum will float to the surface.

This process can be enhanced by mixing a coagulant into the water (such as alum), to make small solids stick together (flocculate) and settle faster.

Water can either slowly flow horizontally through a tank or vertically, with the sediment forming a horizontal suspended layer.

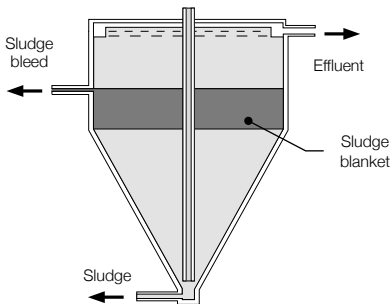

Figure 5. Sedimentation

Filtration: Various types of filters may be used:

Roughing filters have a coarse media, and actually promote settlement as well as filtration within the media. They are used for treatment early in the water treatment works.

Rapid gravity filters are a standard method of treating water. Settled water is passed through a layer of coarse sand to remove silt.

Direct filtration is rapid filtration without a settlement stage. These filters require backwashing frequently.

Pressure filters operate in an enclosed vessel under pressure. This reduces the need for pumping in some circumstances, but requires careful operation.

Slow sand filters have a fine sand media and can also reduce pathogens. They are simple to use.

Membranes are complex to operate but can provide a high quality level of treatment.

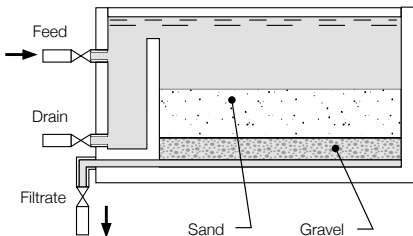

Figure 6. Filtration

Disinfection: Adding chlorine to the water not only kills many pathogens, but also provides a level of protection from recontamination in the distribution system. Complex chlorine dosing systems use chlorine gas, but liquid or solid chlorine compounds are also available and can be used manually. The treated water needs to be stored for a while to allow the chemical to work. The effectiveness of chlorination is reduced for water that is dirty or is likely to be re-contaminated, so priority should be given to cleaning the water and ensuring it stays clean before disinfecting it.

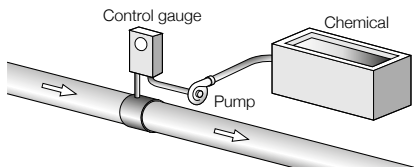

Figure 7. Disinfection

Treated water storage: The supply and demand for water varies throughout the day; to cater for this variation, a tank is used. This also provides water for use in emergencies - such as for fire fighting or for short breakdowns in the water treatment works.

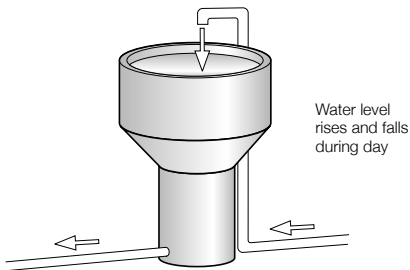

Figure 8. Storage

Distribution: Once the water treatment works is producing water, this can then be distributed to the population. Tankers may be used if the piped system is out of use.

Further reading

LE CHEVALLIER, M.W. and AU, K.K., 2004. *Water Treatment and Pathogen Control: Process efficiency in achieving safe drinking water*, WHO/IWA Publishing. [Online]. [Viewed 13/02/17]. Available from: http://www.who.int/water_sanitation_health/publications/water-treatment-and-pathogen-control/en/

TWORT, A.C. et al., 2000. *Water Supply*, 5th edn. London: Arnold with IWA Publishing.

SPHERE (2011). *Humanitarian Charter and Minimum Standards in Disaster Response*. Geneva: The Sphere Project. (Distributed worldwide by Oxfam GB) <http://www.sphereproject.org/>

About this note

Prepared for WHO by WEDC.

Authors: Brian Reed and Bob Reed

Edited by Rod Shaw

Series Editor: Bob Reed

Graphics by Ken Chatterton.

Designed and produced by WEDC.

**Water, Engineering
and Development Centre (WEDC)
School of Civil and Building Engineering
Loughborough University
Leicestershire LE11 3TU UK**

Phone: + 44 (0) 1509 222885

Email: wedc@lboro.ac.uk

Website: wedc.lboro.ac.uk

Twitter: [wedcuk](https://twitter.com/wedcuk)

YouTube: [wedclboro](https://www.youtube.com/wedclboro)

**World Health Organization
Water, Sanitation, Hygiene and Health
Unit, Avenue Appia 20, 1211, Geneva 27,
Switzerland**

Phone: + 41 22 791 2111

Phone (direct): + 41 22 791 3555/3590

www.who.int/water_sanitation_health

© World Health Organization 2013. All rights reserved.
All reasonable precautions have been taken by the World Health Organization to verify the information contained in this publication. However, the published material is being distributed without warranty of any kind, either expressed or implied. The responsibility for the interpretation and use of the material lies with the reader. In no event shall the World Health Organization be liable for damages arising from its use.



BACK TO TOP
.....

Note: Click on the home icon wherever it appears to return to the list of subjects.
