

4

Abstraction methodology

IN THIS CHAPTER:

- Principles of sand-abstraction
- An overview of different abstraction systems
- Suggestions where each might be used and the advantages and disadvantages of each system
- Pumps and methods of drawing water from each sand-abstraction system:
 - Well-points
 - Infiltration galleries and collector wells
 - Caissons and sand wells
 - Related systems and the development of inadequate sites – sand dams, sub-surface-dams, wadis, hafirs, gabions, sand and gravelbeds

Description of abstraction systems

With the introduction of modern sand-abstraction several systems have been developed that enable the withdrawal of water from saturated sediment. Each system requires equipment that can be installed into water-bearing layers and that will obstruct the entry of sediment. For a system to continue to be effective it must remain at all times in saturated sediment which allows adequate transmissivity.

Water has to be separated from sediment
so that it alone may be abstracted

Present-day sand-abstraction water supply systems range in size from small-scale hand-operated systems through to large schemes powered by diesel engines or electric motors. Smaller systems are typically used for domestic purposes or as water supplies for livestock. Larger systems invariably provide water for irrigation or for larger domestic use such as

farms, hotels and safari camps and can include complete water supplies for small towns.

Principles of abstraction — separating water from sediment

The success of each abstraction system is dependent on the optimum separation of water from sediment through the creation of a graded barrier within the sediment at the point of water abstraction. This requires the formation of a natural filter to prevent the passage of fine sediment. An artificial screen is required in order to create such a filter.

As water is initially drawn through a well-point screen it will contain fine grains from the sediment body in the immediate zone around the screen. Depending on the dimensions of the screen aperture, fine grains of sediment easily pass through the apertures but larger grains lodge against each other and are not drawn through. Smaller grains then in turn wedge against larger grains until there is no further passage of even the finest grains of sediment. In this way a natural filter is created around a well-point or infiltration gallery. Figure 4.1 shows the formation of a natural filter that has been created by drawing fine sediment through an artificial screen.

The dimensions of an artificial screen aperture are usually determined by the size and proportion of sediment grains within a sample of the sediment at an abstraction site. In order that a screen does not impede the flow of water from the alluvium the open surface area should correspond directly to the porosity of the alluvium.

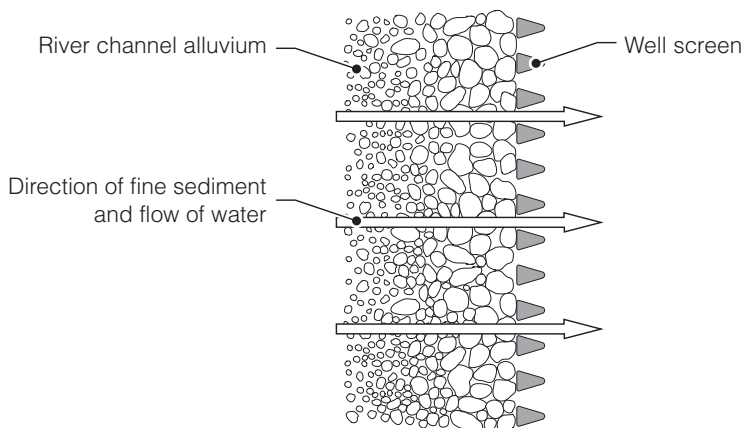

Figure 4.1. Naturally developed sand filter

Ideally screen apertures should allow no more than 60% of sediment grades to pass through into the well-point. Borehole screen manufacturers typically state that the ideal screen should restrict the movement of 30 to 60% of all sediment grains. If greater than 70% of the sediment grade is drawn through the screen during the development of the natural filter slumping may occur around the borehole casing. However, this is not as critical in a sand river aquifer which is relatively shallow in depth and is not itself stable. This criteria may not always be possible, particularly where screens are home made, and in reality even a 10% restriction will generally be seen to work. If, however, the apertures are so large that a natural screen does not develop, the continual passage of sediment through the system will cause undue wear within the pump and abstraction system.

When the natural filter has been adequately developed, blockages at the screen face will be minimized and the void ratio in the immediate zone of abstraction will have been enlarged allowing a greater flow through the screen. Ideally the flow of water through the sediment will be laminar as shown in Figure 4.2 and will create no disturbance of particles that might cause a breakdown of the natural filter zone. In this way the sediment will remain undisturbed and the filter will continue to exclude the flow of fine sediment into the system, unlike turbulent flow that might dislodge particles that would allow further smaller particles to pass through the screen into the abstraction system.

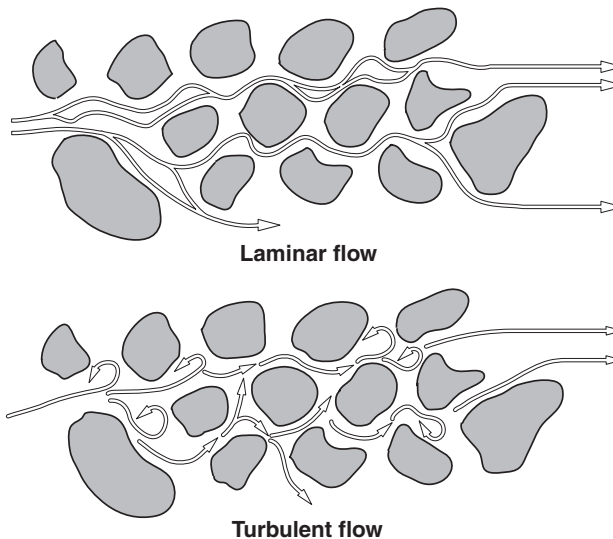

Figure 4.2. Flow of water between particles

A continuous slot screen is shown in Photograph 4.1 positioned within sediment that has been adequately developed as a natural filter. The principle of separation through the development of a natural filter applies whether the abstraction system uses a well-point, an infiltration gallery, a caisson or a well shaft.

The development of a natural, fine filter in sediment around a well-point screen also means that the water drawn from the sediment has been naturally filtered and is invariably safe water suitable for domestic use with few if any contaminants present. Typically there will be very little mineral salt contamination unless there is considerable abstraction from the river channel alluvium to the extent that there is excessive recharge

Where systems of separation are inadequate there will be excessive wear and breakdown of pumping equipment, pipe work will become clogged and the water unpalatable or unusable due to sediment in suspension in the water.

Photograph 4.1. An adequately developed natural filter

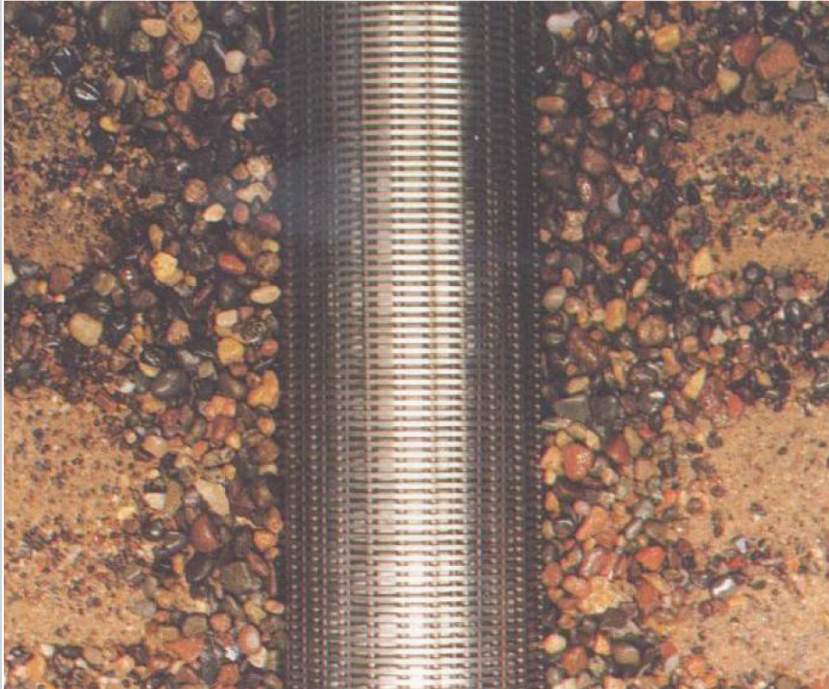

F. G. Driscoll

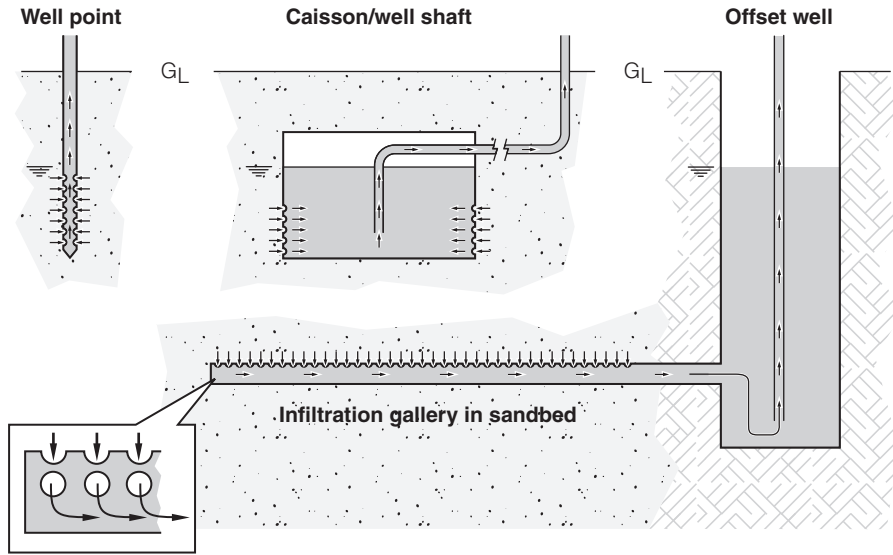

Figure 4.3. Types of abstraction equipment

and drawdown in the riverbank. If this occurs the mineral salts present in the soil are drawn into the alluvium from the riverbank and are then abstracted with the water.

Explanation of methods of abstraction

Methods of water/sediment separation

- Well-points (also known as well-screens or sand-spears)
- Infiltration galleries
- Caissons and sand wells

The basic systems of water/sediment separation equipment are shown in the schematic representation Figure 4.3. The illustration is not to scale.

Well-point

A well-point is a short cylindrical screen that is generally installed deep into the sediment in a river channel. Flow into a well-point is created by a pump which reduces the pressure within the pipe to less than that of the atmosphere, so that atmospheric pressure forces water into the well-point. Figure 4.4 represents a handpump well-point system to draw water from a sand river channel and pump it to a garden site above.

At installation a pump is used to develop the graded barrier around the screen and to draw water to the surface. A single well-point system can be directly coupled through a connecting pipe to a pump on the riverbank. Larger schemes comprise several well-points that join into a single manifold, (a larger diameter pipe), that is connected to one or more pumps on the riverbank.

Infiltration galleries

An infiltration gallery is a slotted or perforated pipe installed horizontally into the alluvium in a riverbed. Water flows from the sediment into the pipe through the pressure exerted by the hydraulic head of the aquifer. It then flows through the gallery pipe to a collector well in the riverbank. From the base of the well water can be drawn to the surface by a pump or possibly siphoned or gravitated to the surface at a lower point. The flow of water into the infiltration gallery develops a graded filter in the same manner as a well-point system but in this instance it is created by the natural pressure of the hydraulic head above the infiltration pipe.

The length of screen in an infiltration gallery will generally be of a greater length or diameter than a well-point as flow into the gallery is the result of the hydraulic head alone. In a typical riverbed aquifer the hydraulic pressure will be significantly lower than atmospheric pressure; consequently a greater surface area of screen is required to abstract water through an

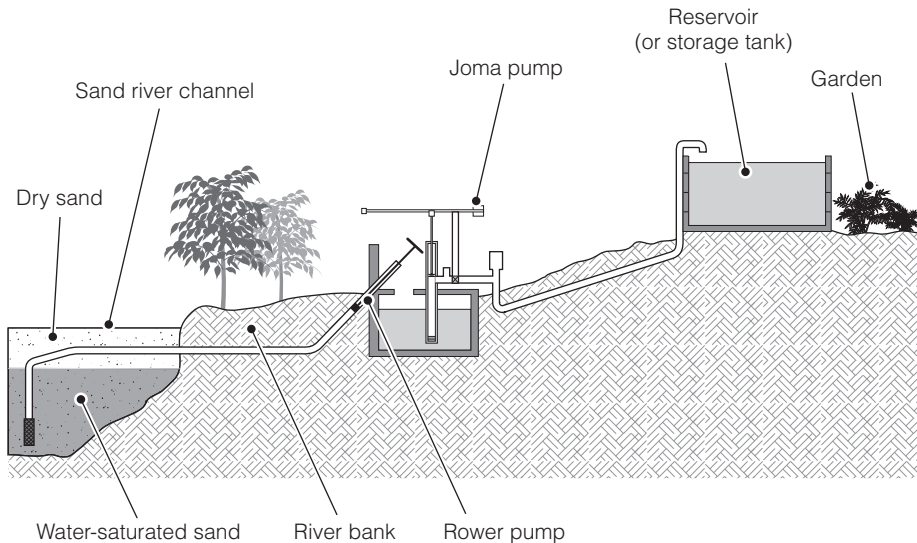

Figure 4.4. Layout of a simple well-point sand-abstraction system

infiltration gallery system than from a well-point. Thus in order to achieve the same yield, infiltration galleries will be either significantly longer or greater in diameter than individual well-points.

Infiltration galleries are often installed in shallow or fine sediment beds where there is poor permeability so that the increased length is of considerable advantage. Figure 4.5 indicates the layout of a typical infiltration gallery.

An infiltration gallery is a permeable, horizontal or inclined conduit into which water infiltrates from an overlying or adjacent source

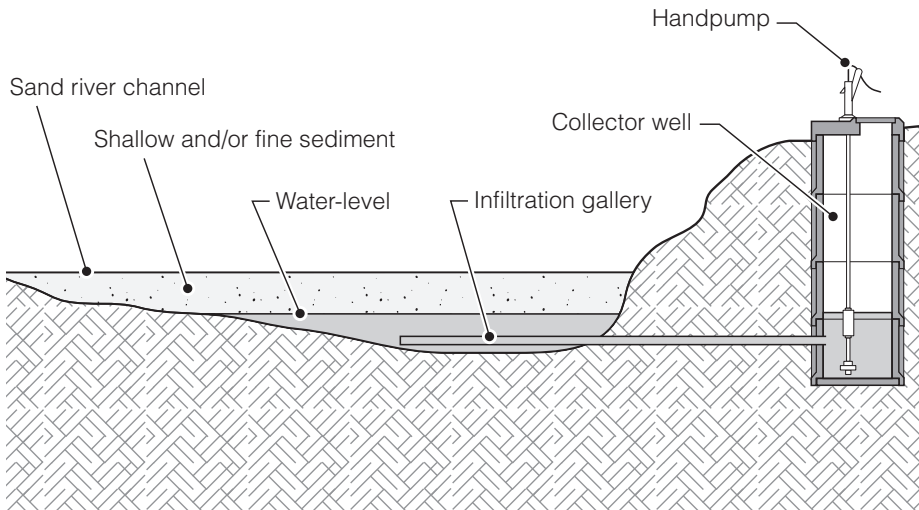

Figure 4.5. Cross-section of an infiltration gallery and collector well

Caissons and sand wells

Caissons and sand wells are typically larger structures than well-points or infiltration galleries and are installed directly into the riverbed or into alluvial riverbanks where there is high permeability. An offset sand well installation is installed in a riverbed and set into the riverbank as indicated in Figure 4.6. The lower sections of the wells are permeable so that water flows from the sediment into the well and eventually creates a graded filter around the base of the caisson or well shaft.

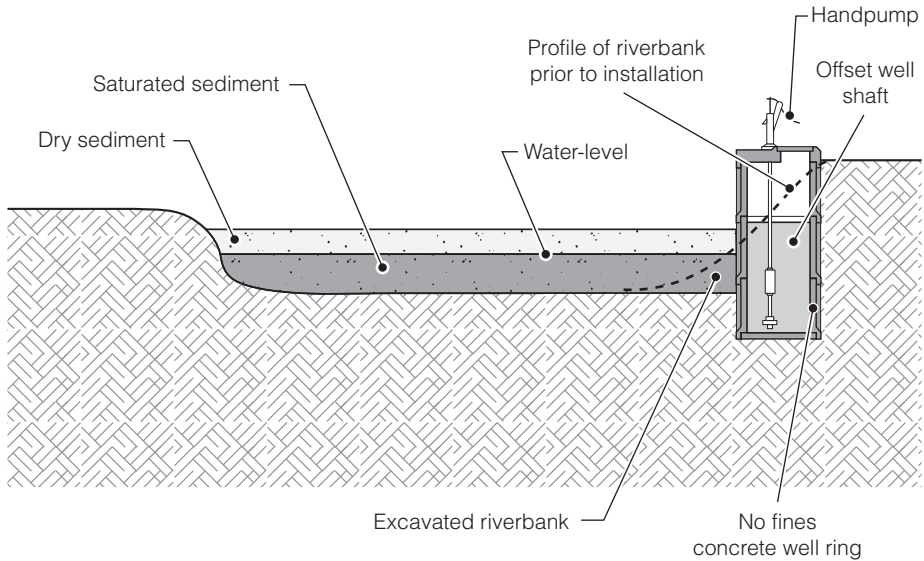

Figure 4.6. Cross-section of an offset sand well

Methods of water abstraction

Once water is free of sediment a pump or water lifting device is required to raise it to the point of use. Small-scale well-point systems require suction pumps offset on the riverbank to draw off water. Both piston and centrifugal pumps are suitable and can be used on single and multiple well-point systems. Electric submersible pumps may be used in conjunction with larger diameter well-points where the pump can be installed direct into the well-point.

Where water is abstracted from a collector well that is offset on a riverbank any type of piston, centrifugal or submersible pump may be used. However, where a caisson or well is sited within a river channel and is subject to flooding, a basic abstraction system, such as a rope and bucket will be a better option. A submersible pump is a possible option in a sand well, provided the power cable and the delivery pipe can be installed below the level of sediment that will be transported to avoid damage.

A sand-abstraction system is as reliable as its weakest component. Provided the screening remains undisturbed there is little to go wrong. To ensure sustainability the pump system should thus be as simple, basic and reliable as possible.

Handpumps provide a low-cost, sustainable solution for small-scale systems

Chapter 6 provides a detailed explanation of suitable pumps and pump applications.

Sand-abstraction systems

Equipment, use, situations and suitability

Screened well-point systems

Well-points are typically used where there is deep sediment within a river channel or alluvium. They are usually a cylindrical screen, some 32 to 200mm in diameter and are relatively short, generally only a half to 1.00m in length but may be up to 3.00 or 4.00m long where sediment is deep. Figure 4.7 shows a non-commercial round aperture, driven well-point.

Apertures are usually round perforations or slots, longitudinal or transverse to the tube. Slots may be straight or taper sided. A taper sided slot is radial and generally in a continuous spiral. It is wider on the inside of the screen than on the outside so that grains of sediment that enter the aperture do not become wedged within the slot as shown in Figure 4.8. Slots may also be embossed and louvered, open at the top, the bottom or both.

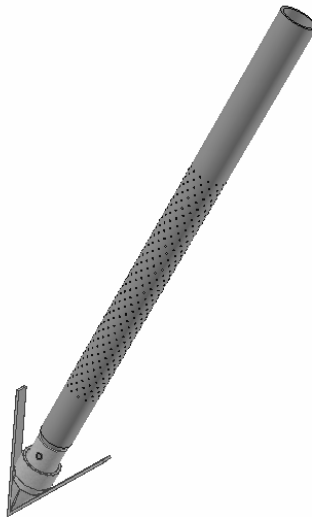

Figure 4.7. Round aperture well-point

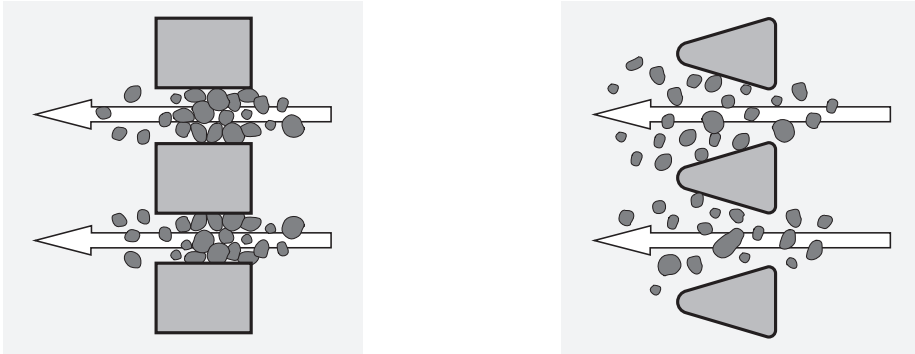

Figure 4.8. Parallel and taper slots

There are numerous designs of both well-points and screens and a variety of materials can be used in their construction. The screens may be made of uPVC, ABS or plastic, stainless steel, galvanized water pipe, copper pipe or wire-wrapped pipe and can also be made of concrete, fired clay, synthetic fibre or organic fibre. The apertures in the screen may be perforated, slotted or louvered; of detailed dimension and placement or random and tortuous. With slotted screens the slots may be short and transverse, long and longitudinal or a continuous spiral. In cross-section slots may be straight or taper-sided. Whatever the design each successful system is dependent on creating an extended filter within the sediment.

Well-points are generally installed vertically or obliquely into sediment and are inserted into the sediment either through driving or jetting, or simply through digging in. The installation should be as deep as possible in order to ensure that the well-point remains in water.

Well-points are easy to handle as they are small, short and lightweight. They are usually quick and easy to install and do not require complex pumping equipment. They are particularly effective in relatively deep beds of coarse river sediment in rivers of any width, although they are best suited where an abstraction site can be located within 30 metres of the riverbank.

Photograph 4.2 shows a sand river site best suited to a well-point and suction pump system. The river channel is wide, the gradient of the river low so there is a likelihood of an adequate depth of sediment and the riverbanks are low so that water can be delivered to the riverbank by a suction pump using atmospheric pressure.

Photograph 4.2. Chibabe River, Matabeleland South, Zimbabwe



Infiltration gallery system

One or more infiltration galleries are often installed together with a collector well where there is a reliable water supply, but where the sediment is shallow or fine and of poor permeability. The diameter of a gallery pipe generally varies from some 75mm to 300mm but may be as much as 500mm depending on the supply of available water. The length of an infiltration gallery may be as short as a few metres or as long as several hundred metres. An infiltration gallery induces the same mechanical separation of water from sediment as a well-point. Water enters the gallery from alluvium and is discharged from the gallery by the hydraulic head. However, there is generally only a small hydraulic head above an infiltration gallery and thus the screen section required will be of considerably greater length than a well-point screen.

In a small-scale scheme a single gallery pipe may be placed either across or along a river channel to discharge straight into a collector well on the riverbank. Where a single gallery is not practical, two or more pipes in a 'T' a 'V' a 'Y' or a triple forked ($\backslash /$) configuration can be installed in the river channel to increase the surface area for abstraction or as short lengths where the river is fast flowing. Large schemes invariably comprise a system of infiltration pipes placed in a herringbone or parallel grid system that discharges to a larger manifold that in turn delivers water to an abstraction point. Depending on their length a single or double gallery is generally sufficient with smaller schemes. Figure 4.9 indicates suitable gallery layouts related to channel width.

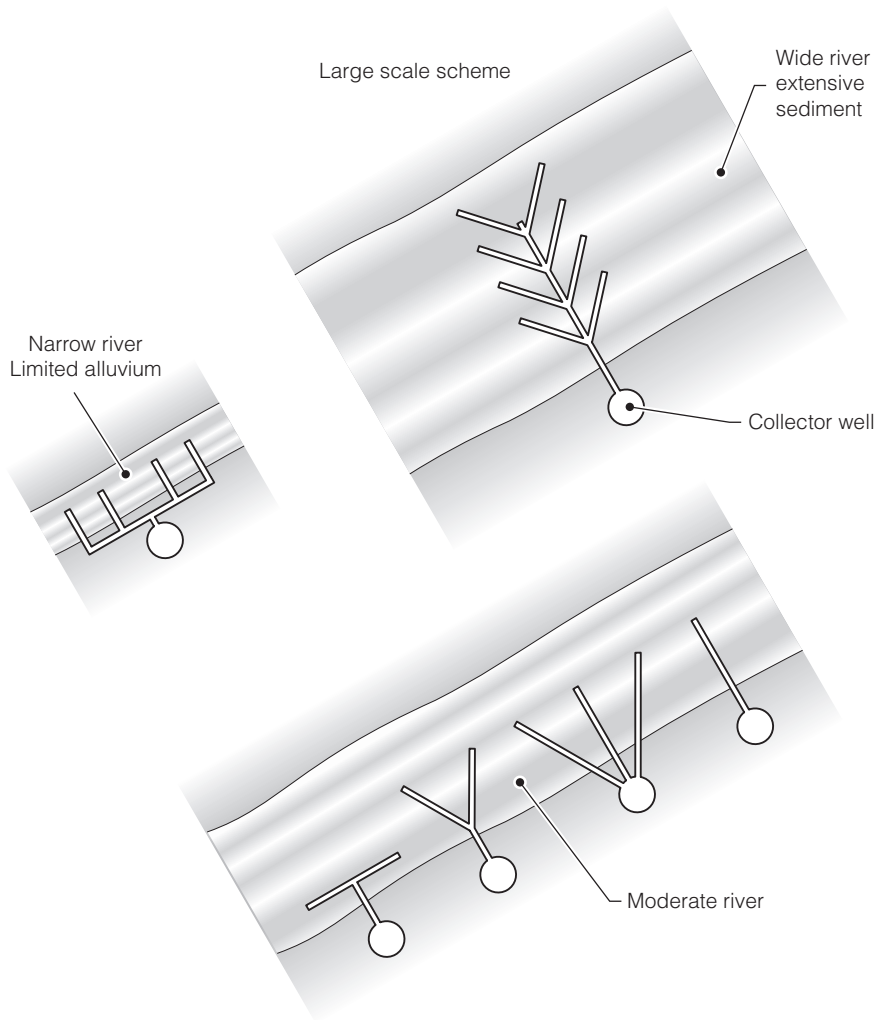

Figure 4.9. Infiltration gallery layouts

A successful installation necessitates much digging into both the river sediment and the riverbank to ensure that a satisfactory depth is reached that will keep the abstraction pipes in water bearing sediment. Unless earth-moving equipment is used, or shuttering has to be installed to shore the sides of the excavation, it is a relatively inexpensive system and does not require complex equipment or expertise to operate or maintain. Water abstraction systems may also be low-tech, requiring only a basic handpump or even just a simple windlass to draw water from the collector well. However, although a suitable technology in the right situation, it is difficult

Photographs 4.3 to 4.7

Infiltration well, Rundi River, Midlands, Zimbabwe



to ensure that any system of infiltration gallery is installed sufficiently deep in the sediment of seasonal rivers to be maintained in water at all times. In an ideal installation the infiltration pipe would be installed one metre deep in saturated sediment and if more than one, no closer than 3 metres apart and of a sufficient length not to create drawdown.

The collage of pictures (Photographs 4.3 to 4.7) shows a site where an infiltration gallery is best suited. The pump is installed high up on the riverbank where it cannot be damaged by flood water when the river is in spate. As the suction head precludes the use of an atmospheric suction pump a borehole pump has been used on the collector well. The pictures show the excavations and installation of a small-scale infiltration gallery, collector well and handpump scheme at Wasarawasara garden on the Rundi River, Zvishavane, Zimbabwe.

Infiltration systems do not necessarily need to be complex. In some situations rock-filled galleries have been used instead of infiltration pipes and as long as there is sufficient recharge through the soil to offset the pumping rate with existing head conditions, no gallery may be required at all. However, in any infiltration system the abstraction rate must not exceed the recharge rate and the flow to the wells must remain as close as possible to laminar so that sediment is not introduced into the well.

Infiltration gallery systems are particularly suited to installation in perennial riverbeds. They have been used with great success as small-scale water supplies at remote locations on the Scottish Isles through to water treatment and supply solutions for several cities in the North American mid-west, as well as a source of water to parts of New York City and Los Angeles.

Caisson system

Caissons and sand wells both use large diameter screen systems installed into sediment. The screens are typically from 500mm to 3m or even 6m in diameter and allow direct access to water. They can be installed straight into the sediment of a river channel or on a riverbank where there is alluvial soil with a high permeability. A caisson can be considered to be a well shaft that does not reach the surface. It is generally covered by a slab with a narrow diameter connection either vertically to the surface or horizontally to a sump on the riverbank.

Photograph 4.8 shows a sand river site that would be suited to water abstraction through a caisson or hydrodynamic well. The site comprises a

WATER FROM SAND RIVERS

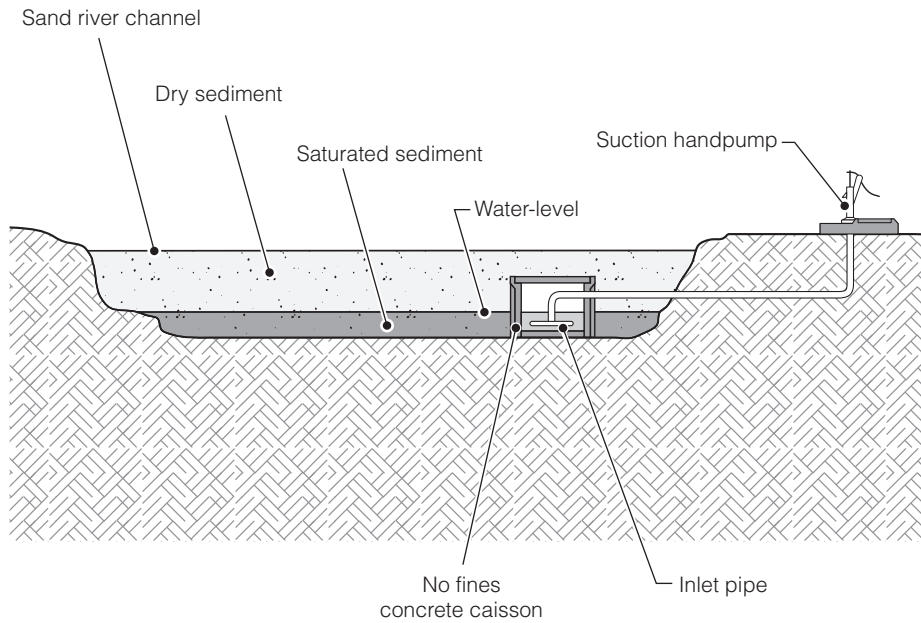

Figure 4.10. Riverbed caisson

Photograph 4.8. Dongamuzi River, Matabeleland North, Zimbabwe



narrow stream with a low water retention potential where a large diameter shaft can be constructed deep in the centre of the channel to draw water from a large area.

In the lower sections caissons and wells are typically constructed of no-fines concrete or brickwork with no mortar between the vertical joints but also may be of steel or fibre-glass and slotted or drilled to create a screen. A caisson is typically cylindrical and depending on the nature of the screen and the diameter of the caisson, screen entrance velocities are likely to be particularly low, sufficient to maintain laminar flow to the screen. Such a large surface area within water bearing sediment and the subsequently low transmissivity rates make caissons particularly suitable for use in fine sediments.

Due to the mass of a caisson, it is necessary to install the structure on the floor of the riverbed for stability. The well-rings should not extend to the surface sediment but remain a half metre or so below the surface of the sediment to reduce the surface area when the river flows and when sediment and debris are transported through the channel. The well shaft is covered with a concrete slab and water is abstracted from the well by a suction pump which is sited in a sump on the riverbank or from a submersible pump installed within the caisson. Figure 4.10 shows a type of riverbed caisson that has been used on small rivers in Botswana by the Rural Industries Innovation Centre (RIIC), Kanye, Botswana.

The system is more awkward to install than a well-point system due to its bulk and the digging required to lower it onto the riverbed. Because of the large surface area from which abstraction takes place it may be possible to use a caisson where silt accumulates. However, although water can be drawn from very fine sediment, recharge will be slow, particularly where there are layers of silt to impede the flow of water to the abstraction zone of the caisson and thus abstraction may not ultimately be successful in silt conditions. Photograph 4.9 shows the installation of the solid upper sections of several concrete caissons which will be connected by a manifold.

Sand well system

The most basic method of drawing water from a sand river is from an open depression excavated in the river sediment, referred to as a sand well or scoop well. The natural upgrade of this traditional form of open well is a lined well. However, a dug well direct into river sediment is liable to be damaged by river flow, either demolished by the flow of water or in-filled by sediment.

Photograph 4.9. Installation of concrete caissons in the Rundi River, Zimbabwe



Sand wells are thus best installed into alluvial riverbanks close to the river channel where they can draw water from the river alluvium or dug into the side of the riverbank where they can interface directly with the sediment in the river channel as shown in Figure 4.11.

A sand well, as in Figure 4.12, that can be installed within a river channel and that allows floodwater to pass over without damage or any in-filling has been designed by Erik Nissen-Petersen, ASAL Consultants, Nairobi, Kenya. The well shaft is constructed from radiused concrete blocks with the lower eight courses laid without building mortar to allow infiltration into the well. The top of the well protrudes from the surface of the river sediment and is surrounded with rock and rubble overlaid with concrete. This headwork is of a hydrodynamic shape and has a cover to prevent river sediment filling the well shaft. The shape of the well head is akin to that of an up-turned boat, which allows water to flow around and over the structure and does not collect the debris carried by the river. This debris could build up around the well head and lead to its being washed away or to the destruction of the well shaft. Such a structure is probably best used within the sediment of river channels with low porosity and poor permeability. Here excavations can be made to the riverbed and the sediment has some stability, with little sediment transported through the river channel. In these conditions a degree of protection can be expected for a sand well shaft.

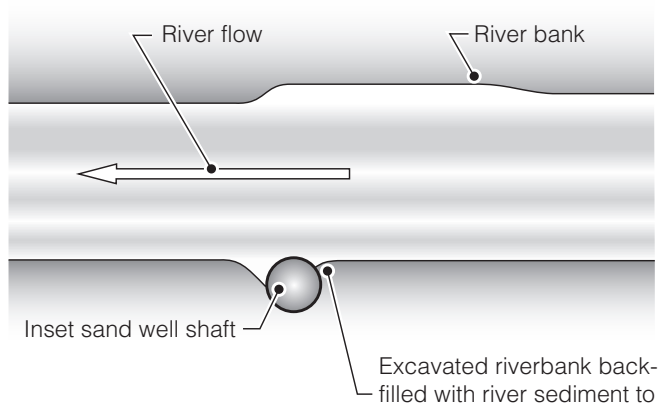

Figure 4.11. Riverbank site of an offset sand well

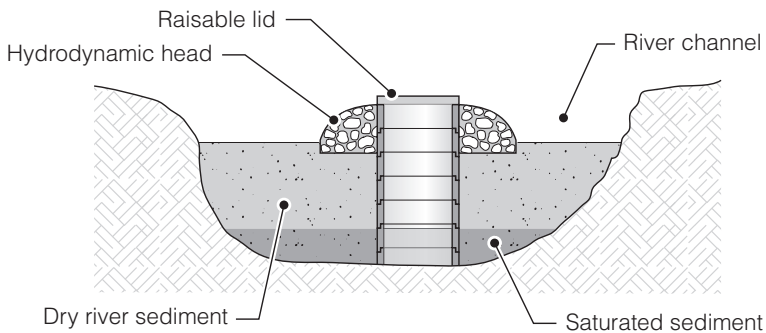

Figure 4.12. Hydrodynamic well head in a sand river channel

Each system, whether well-point, infiltration gallery, caisson or sand well requires installing into river sediment as deeply as possible. As the water-level drops during the dry season so it may be necessary to lower the screen or water separation area in order that water may continue to be abstracted satisfactorily. An installation is only complete once a level has been reached where the screen remains in water year round. This process may be achieved within a year or over several years with the final depth only being reached in a particularly dry year when the water-level in the river channel is at its lowest.

In adverse situations, especially in seasons of inadequate rainfall it is possible that alluvial river water sources become so depleted that abstraction systems run dry. An open system such as a sand well then has an

advantage as there will generally be a small quantity of water, perhaps too small to be pumped, that will seep into the well and can be collected.

Related systems and alternative sources of water from sand

The use of sand-abstraction technology is appropriate wherever alluvium is unconsolidated. Alluvium refers to sediments deposited by flowing water and thus occurs in fossil riverbeds, the sub-surface sand and gravelbeds of paleo river channels and some of the flats alongside present-day river channels. The artificial formation of beds of alluvium in sand dams and hafirs (hafayer) create an additional clean water storage resource.

Sand dam

In situations where there is a limited accumulation of river sediment, water is only retained for short indeterminate periods during the rains. Although water losses from leaching, drainage and evaporation are lower

Photograph 4.10. Mkayi Wokhoza sand dam under construction



from sediment than from open water it is not always possible for water to be retained year round in all sediment beds. The construction of an open surface dam will increase the supply of available water but in dryland areas with high rates of environmental degradation and subsequent erosion there is often excessive siltation that may render a small dam useless in just a few seasons. However, where coarse sediment can be accumulated in a dam basin, water will be retained as if it were in river alluvium. Increasing the volume of sediment creates a larger water storage area. A sand dam, as shown under construction in Photograph 4.10, retains the sediment which is carried by the stream or river. The water is retained in the pore space in the sediment thus improving the supply of clean water and reducing the loss from evaporation.

In order to retain coarse sediment a sand dam is constructed in stages to a height generally not exceeding 1m in the first year and no more than 0.5m metres in each subsequent year. In this manner coarse sand is deposited behind the dam wall and the finer, lighter sand particles are transported over the wall. The construction process of a sand dam is shown in Figure 4.13. Through this construction technique the fine silt which would clog and limit the water storage capacity of the dam is not retained. The coarse material that is deposited constitutes a highly permeable medium with a large water storage potential.

As the spillway of a sand dam is constructed above the level of the river sediment, the masonry wall is built in steps in order to reduce the velocity and height from which the water falls thus preventing scour and undercutting of the wall that might lead to collapse. Water can be drawn from a sand dam through a sand well or below the weir through gravity by way of a pipe connected through the wall to an infiltration gallery laid at the bottom of the sediment. Vertical pipes can be connected to these to ensure that any silt layers which have formed do not seal the upper saturated layers from the abstraction pipes.

An advantage of a sand dam is that it acts as a large, natural, slow sand filtration system through an aerobic filtration process of sedimentation, straining, adsorption and chemical and bacteriological action. These processes are an effective method of removing impurities such as fine silt, organic matter, bacteria and most mineral salts.

Although not primarily intended to store water, erosion control methods may also yield useable quantities of water. Small dams, often called Check dams are small walls bonded into the base and sides of a gully to retain eroded topsoil in transport. Check dams can be constructed of locally

available stone, either built with mortar or as a dry-stone wall. In effect they act as a micro sand dam by retaining water in the alluvium of the gully and also contribute to the recharge of groundwater. As check dams retain eroded material so they rehabilitate gullies and improve land that has deteriorated through erosion and where they retain sufficient water they may be used as a sand-abstraction water supply.

Sub-surface dam

A sub-surface dam increases the water storage potential of riverbeds where there is already a significant depth of sediment, but where due to excessive downstream drainage water is not retained year round. In areas

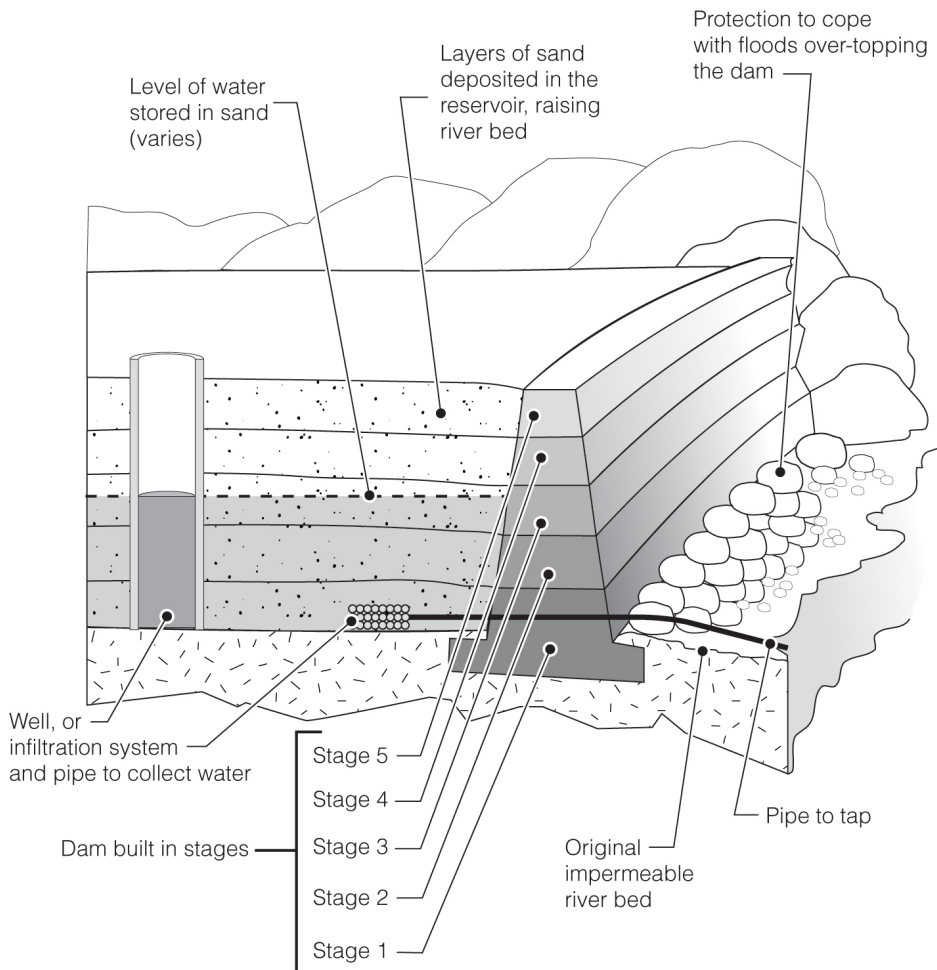

Figure 4.13. Construction process of a sand dam

where rivers have little slope many rivers have become so full of deposited sediment that the entire channel is clogged with alluvium. In particularly flat areas the river channels in some drainage systems are so clogged that when in flood the riverbanks are over-topped and extensive areas are liable to flood.

Where there is no appreciable basin the construction of a dam or a sand dam is not feasible, however the construction of an impermeable barrier within the sediment of a river channel will raise the water-level, reduce downstream drainage and entrap water which otherwise would be lost. Photograph 4.11 shows a sub-surface dam on the Swakop River, Swakopmund, Namibia that is constructed between a cliff on one side of the river and extensive wind blown sand dunes on the other.

A typical embankment dam or weir not only stores surface water in the open dam basin but through infiltration also in the sub-surface both below and upstream of the dam. A wall that is constructed on solid material in the base of a river channel and built to the same criteria as a regular dam will retain water in the sediment of the river channel and in the adjoining aquifer, thus reducing the loss of downstream drainage. In this manner there is an increase in the volume of stored water that can be abstracted.

As a sub-surface dam wall is supported by sediment on both the upstream and the downstream sides and as there is no increased velocity or vertical drop of water to absorb, where there is not excessive sediment transport

Photograph 4.11. Sub-surface dam Swakop River, Swakopmund, Namibia



through a river channel the construction of a sub-surface dam wall may be less substantial than that of a masonry, brick or concrete weir. However, as there is transport of sediment across the dam wall during river flow, depending on the volume of flow the top of a sub-surface dam wall should only be constructed to some 500mm below the sediment surface in order to minimize turbulence which in turn would reduce scour and loss of sediment that might lead to undercutting of the dam wall. The equipment and installation procedures used in sand-abstraction are equally applicable for the abstraction of water from a sand dam or a sub-surface dam.

In some river situations it is possible to construct a sub-surface dam using an impermeable membrane rather than a substantial dam wall. The process is both simpler and less costly to construct as it uses only polythene or butyl sheeting to create a barrier. A trench is excavated in the sediment of a seasonal river across the channel and to the base of the riverbed. The downstream side of this trench is lined with polythene sheet and the trench back-filled to leave a vertical, impervious membrane across the river to reduce losses of downstream sub-surface flow.

There are however, difficulties associated with the construction of a membrane dam:

- The river channel sediment must be fine and compacted as it is difficult to safely excavate a narrow trench in coarse unstable sediment, certainly to reach a depth where a satisfactory seal can be achieved between the riverbed and the membrane.
- The upper portion of a membrane may be damaged during periods of sediment transport through the river channel.
- A membrane is unlikely to be a permanent solution as it may well require replacing each year.

Wadi

Wadis differ from other ephemeral or seasonal rivers as they are essentially endogenous rivers in very arid or desert regions. A wadi carries the flash floods that occur following isolated but heavy sporadic rain, and generally has no defined source and no outlet although they may discharge into the desert. The volume and duration of flow in a wadi reacts directly to the intensity and duration of the storm creating the flow. Depending on the geology, the terrain and precipitation patterns, wadis range from short, sand-filled ravines to very shallow waterways, half a kilometre or more in width that are almost indistinguishable from the surrounding land as indicated in Photograph 4.12. Whichever waterway formation, when there

has been sufficient precipitation to induce run-off, water collects in wadis and as the alluvium is unconsolidated, sand-abstraction technology can be used to draw water.

Sand wells have been successfully constructed in wadis in south-western Ethiopia and check dams constructed across wadis and gullies have been used to increase water supplies in several dryland areas.

Water losses in a wadi are typically high and in the Middle East attempts have been made to rapidly infiltrate water from a wadi into the sub-surface for groundwater storage. Further efforts have been made to link several small wadis through galleries or qanats to increase water reserves.

Photograph 4.12. Wadi, West Darfur, Sudan



B. R. Henson

Other systems of storing water in sand

Sand-filled water storage tanks — hafir

Pastoralists in the Ogaden and Horn-of-Africa traditionally store water in a hafir, an excavated, unlined pit that collects water from a nearby waterway or wadi. Hafirs are common sources of water storage in central Sudan where they range in size from 5,000 to 1,000,000m³. Because they harvest run-off water hafirs are prone to extensive siltation but when silted may not be rendered completely useless if it is coarse sediment that has been trapped.

The water storage period of hafirs can be increased by lining the pits with cement mortar or plastic, uPVC or butyl sheet. Smaller tanks have also been constructed that catch water from aprons or roof water collection systems. To reduce water loss by evaporation these tanks can be back-filled with sand and to increase their water storage capacity they may also contain porous hollow domed structures, sometimes referred to as ‘beehives’. The design of a sand-filled hafir with beehive domes is shown in Figure 4.14.

Although tanks are generally open and used mainly for livestock watering or irrigation, sand-filled tanks have been used for domestic water. One

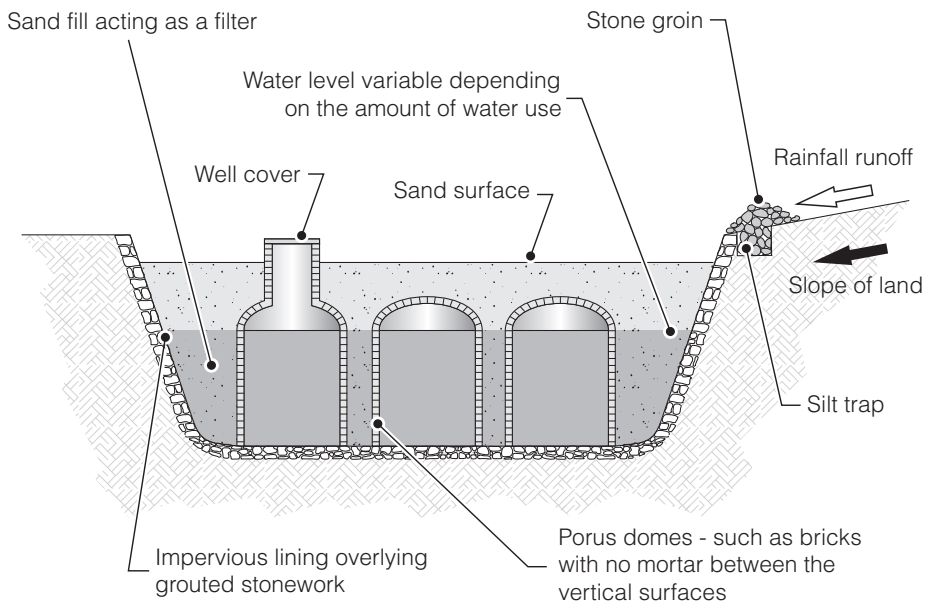

Figure 4.14. Sand-filled hafir with water storage domes

Domestic hafir water harvesting system constructed in Serowe, Botswana for use by a family of five

The system comprised a sub-surface tank of approximately 76.5m³, rectangular in plan and trapezoidal in cross section with dimensions 6.0×9.5m at the surface and 4.8×7.3m at the base. The mean depth of the tank was 1.8m with a slight slope toward the water extraction end.

During construction 24 (6 rows of 4) cylindrical 'tanks' (nicknamed beehives) were erected inside the main tank and extended to 150mm below the top of the tank. Each beehive was made from concrete 'sausages' laid in a vertical spiral and dome-topped with an approximate volume of 1.75m³; total volume of beehives was thus 42m³. The 'sausages' were made from ±400mm lengths of 50mm diameter polythene tube filled with a weak sand/cement mix that was moistened and then held in place with short lengths of 4.00mm wire. These sausages were also used to protect the polythene sheet that was used to line the tank.

The interstitial space in the tank was filled with sand and with the exception of one access shaft the beehives were covered to a depth of 150mm. The domes and the upper sides of the beehives were covered with a sheet of clear 150μ polythene to ensure that water could only enter them after filtering through at least a metre of sand. Assuming an approximate percentage of voids in the backfilled sand of 25% the total water storage capacity of the tank was 50m³.

The sand surface in the hafir was covered with a sheet of 150μ clear polythene, with a further 75mm of sand on top of that for protection. The sheet was pierced all over with a garden fork to allow water to flow easily downwards through it, but restricted capillary rise to the surface to prevent excessive evaporation loss.

Clean water was drawn from the tank by a semi-rotary handpump that was mounted to one side of the hafir with a suction pipe inserted in the end beehive of one of the central rows which protruded above the surface to act as a well shaft.

system in Botswana provided household water from roof and yard runoff that was harvested each year in a sand-filled hafir. The water, which other than its passage through sand was untreated, was hand-pumped from the hafir to a roof tank and provided water for a family of 5 people for 5 years. To increase the water storage capacity of the hafir porous domes which restrained the sand were constructed in the base of the tank.

Sediment accumulation

Gabions, which are rock-filled wire frames or 'baskets', are used in erosion control situations to prevent the transport of sediment in flowing water. Where a series of gabions are placed across a waterway an increase may

be achieved in the depth of sediment deposited within a riverbed. Although in such a system there is no seal or bonding of the gabion to the base of the waterway, the additional depth of sediment constitutes an increase in the volume of alluvium and thus the water storage capacity of the aquifer. The greater body of water is less subject to losses from evaporation and slower to drain downstream.

Sand and gravelbeds

Parallels can be drawn between the technology required to abstract water from sand rivers and the abstraction of water from sand and gravelbed aquifers. The materials and equipment required to draw water from river alluvium are similar to those used to abstract water from sand and gravelbeds. Although the installation technology may differ, a well-point screen is as appropriate in a sand-abstraction application as it is in a tube well or even a borehole. The criteria for screen technology, the slot aperture, shape and dimensions apply equally whether the screen is used in river alluvium, in a sand or gravelbed aquifer, a sand dam or sand-filled water storage tank.

The equipment and methodology required for the productive abstraction of water from sand-abstraction is also used in land drainage and the de-watering of construction sites. The design of materials and equipment required for the rapid absorption or infiltration of water from car parks or the continuous drainage of building foundations and basements, bridge pier foundations and applications such as the drainage of unstable motorway cuttings is also relevant to the technology of sand-abstraction.

Chapter summary

The essence of sand-abstraction is an adequate separation of water from sediment. This can be effectively achieved through the introduction of a screen into saturated sediment that will develop a surrounding graded filter to block the passage of sediment into an abstraction system.

There are a number of ways of preventing the movement of sediment and of creating a natural filter in sediment. A simple and effective method is to use one of a range of screens developed in the borehole industry, or to fabricate a screen using the principle of borehole screening. Screening can be used in relatively short lengths in a vertical position either as a single well-point or in multiple units with water abstracted through a direct coupled pump on the riverbank. Screening can also be used horizontally

in longer lengths that discharge to a collector well set in the riverbank. A further possibility is the use of dug well technology to install caissons or sand wells into the riverbed or offset in the riverbank.

Inadequate sites can be developed through the construction of sub-surface dams that will retain additional water both in the river alluvium and in the adjoining aquifer. The construction of a sand dam or a series of gabions that will increase the volume of sediment in a river channel will automatically create additional water storage capacity. Sand-filled water harvesting tanks provide a further method of water storage that uses the benefits of clean water and reduces evaporation in the same manner as a natural sediment bed.

A decision is now required on which of the systems is the most suitable abstraction system for a particular site and the most suitable method of installing that system into a sediment bed.