

## **Key points about sanitation**

- Provision of adequate sanitation is necessary in order to reduce many common illnesses such as diarrhoea and worm infestations; improving domestic hygiene practices is essential.
- Pour flush pit latrines are widespread in South Asia and are the preferred option.
- Where possible, single deep pits are best as they can last for many years without being emptied; in areas where this is not possible, a double pit system can be used as this reduces the hazards when emptying the pit.
- Solids accumulate in leach pits and septic tanks at a rate of about 40 litres per user per year.
- There will normally need to be separate sullage drains when toilet wastes are disposed of on the plot
- Local standards for the minimum pipe diameter can be used for most tertiary sewers; these are typically 150mm or 225mm.
- The minimum cover on sewers in narrow lanes that do not carry heavy traffic can be reduced from that prescribed by conventional standards. In turn, this allows lower cost inspection chambers to be used rather than conventional manholes.
- The sewer gradient is an important parameter and should be the lower of the minimum allowable gradient and the ground slope. Detailed guidance is provided.

## Section 4c

# Sanitation

---

### **Tool S1 Sanitation: Objectives and options**

---

#### **Objectives of sanitation**

In the context of this manual, sanitation is concerned with the safe disposal of human excreta; good sanitation is aesthetically desirable, and has important health implications. Many common illnesses such as diarrhoea, dysentery and enteric fevers can be transmitted through contact with the excreta of an infected person; the important faecal-oral route of disease transmission is illustrated in Figure S1.

The direct environmental health risks associated with excreta lying on open ground, in pools, ponds, drains and water courses are very high. In communities which lack sanitation, most disease transmission occurs in the heavily contaminated neighbourhood environment independently of household levels of hygiene. In this situation, removing excreta from the immediate environment is the first priority. For example, if half the households in a community are using sanitary latrines, whilst the other half practice indiscriminate defecation in and around the area, then the whole community is still exposed to high levels of environmental health risk. Therefore the most important action is to contain the problem through provision of some form of sanitation for those practising indiscriminate defecation.

A particularly serious problem is indiscriminate defecation by children, whose faeces are particularly rich in pathogens (disease-causing organisms). They are most affected by the main excreted infections and therefore disease control through excreta disposal improvements has particular relevance.

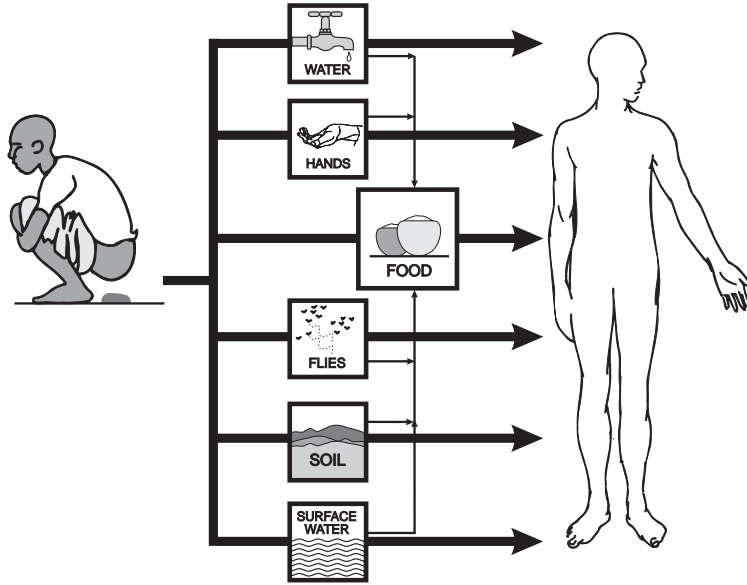

a: Faecal-oral transmission route of disease

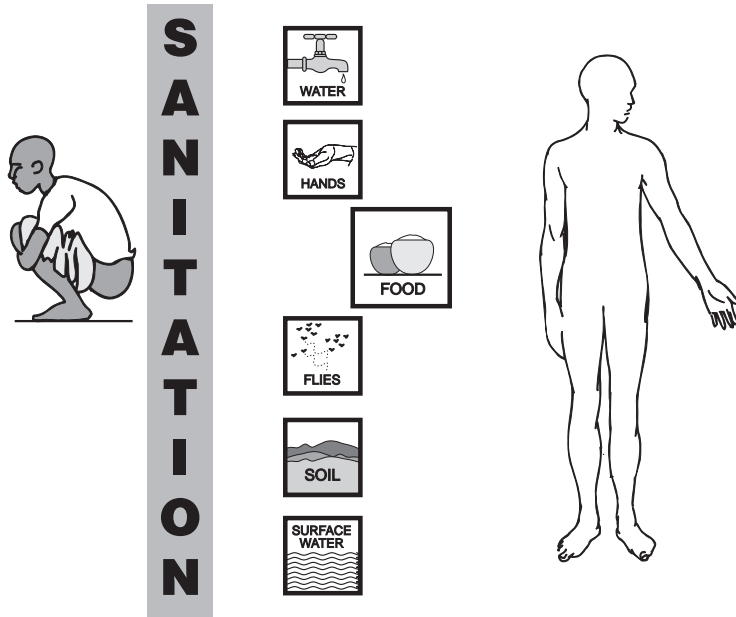

b: The 'sanitation barrier' to faecal-oral transmission of disease

**Figure S1. The importance of sanitation**

The provision of latrines or toilets is thus an important measure in the prevention of excreta-related diseases, in particular through the breaking of the faecal-oral transmission mechanism.

### **Sanitation options**

There are several options for excreta disposal; the following classification is useful from the viewpoint of urban low-income housing.

*'On-plot' sanitation systems* in which safe disposal of excreta takes place on or near the housing plot; pit latrines and septic tanks fall into this category.

*'Off-plot' sanitation systems* in which excreta are collected from individual houses and carried away from the plot to be disposed of; sewerage is the most important option in this category.

The selection of the most appropriate sanitation system is influenced by technical, cultural, financial, and institutional factors; the following points are of fundamental technical importance.

- The quantity of water available for use in the sanitation system. Water requirements of different systems vary from zero to 80 litres per person per day; hence the level of service for water supply is important.
- This cuts both ways: for example, if there is too little water, then sewerage will not function; if there is a high volume of water supplied, on-plot systems will not be able to deal with the quantity of wastewater generated.
- The material used for anal cleansing after defecation; this depends upon the cultural and religious practices of the society, and materials used include water, paper, leaves, sand, and stones.

### **Individual, shared and communal latrines**

From the point of view of the users, the most desirable option is to have an individual household latrine which is used only by the family; the latrine may discharge either to a pit, septic tank or sewer. This is the best alternative, because the household is in control.

However, in many slum areas, housing is of very poor quality, space is lacking, and individual household latrines are not feasible. In these circumstances, the best approach is to use *shared latrines*, based on the principle of restricting access to a clearly defined user group. Many slums contain small corners of land of sufficient size to accommodate a one- or two-compartment latrine. The key point is to identify a small user group for each latrine, which may be shared by several families; experience with this is not well documented, but there is evidence that such latrines are in regular use, are kept clean and are popular with users. Restricted access appears to be the key to success.

Shared latrines are much more satisfactory than the communal latrines which are used by a large number of people and have all too often been used as a standard solution in overcrowded neighbourhoods. Communal latrines rapidly become fouled and unusable unless cleaners are appointed to clean them.

It is important to distinguish between public latrines and communal latrines. Public latrines are provided for the use of the general public in places such as bus stands, markets and other facilities which have a large throughput of people. One of the success stories of Indian sanitation has been the public latrines developed and managed on a pay-as-you-go basis by the organisation Sulabh. This contrasts with communal (or community) latrines which are usually constructed in low income residential areas and slums to provide for the everyday needs of the local population. These work satisfactorily if cleaners are employed. However, in the majority of cases there are no satisfactory arrangements for cleaning. The Sulabh model works well for public latrines, but it is not a private sector panacea for the problems of sanitation in low income urban communities.

### **Management and institutional linkages**

The conventional approach to engineering planning and design focuses on technical options and their feasibility in a technical sense. This approach is questionable in the context of upgrading low income urban areas; there are two key factors which are determinants of success in both implementation and sustainability of sanitation systems:

- the capacity of local institutions; and
- the capacity of local community groups.

In other words, do not choose a technology based on purely technical considerations and then look to see how institutions must be changed in order to implement and manage it. Rather, look at it the other way round; what is the availability of technical, financial and managerial capacity within urban government and local communities to cope with a particular infrastructure. Capacity can be enhanced, but it cannot suddenly be produced from nowhere; the requirements of a particular technical option have to fit in with this local capacity.

## Costs and subsidies

Cost estimates for different sanitation technologies vary both internationally and with respect to the detailed design of the system. Table S1 suggests per capita investment norms for India at 1995 prices and illustrates the relative costs. These clearly indicate the cost advantages of on-plot options.

<b>Table S1. Sanitation investment costs</b>		
<b>Service Option</b>	<b>Cost range, Rupees</b>	<b>Relative cost *</b>
Water borne sewerage	1022-1460	100%
Septic tanks	584-657	50%
Pit latrines	350-438	32%

\* based on mean of range

Operation and maintenance costs are much harder to determine. This stems in part from the fact that budgets for O&M are often made on the basis of cash available at a particular time, rather than on a planned cycle based on actual needs.

The issue of subsidies for sanitation has long been contentious. The extent of subsidy in relation to the different sanitation options is very difficult to establish. It is often much more transparent in programmes aimed at lower income groups; for example, the Government of India Low Cost Sanitation programme offers a subsidy of 40% of the substructure and 5% of the superstructure costs. All operation and maintenance charges will be borne by the users as there is no institutional involvement post-construction.

The extent of subsidy is much less transparent with sewerage. Serious problems exist in getting people to pay a connection fee; in one case there were only 25 registered connections, and the sewerage utility recovered less than 10% of the power costs for mains sewage pumping. There was no cost recovery for maintenance or allowances for capital depreciation. These costs are therefore provided by subsidy; the users do not pay. By implication it is higher and middle income groups which generally benefit from sewerage; tariffs rarely cover the economic cost of service delivery, resulting in very large hidden subsidies. The prime focus of the subsidy and cost recovery argument should lie here; the time to question partial sanitation subsidies to the poor is when the better-off cease to be subsidised on a massive scale. Poverty and indebtedness are probably the most important reasons why families do not have their own latrines. One of the crucial programme planning issues therefore relates to improving access to finance for poor households.

A comparison of sanitation options is presented in Table S2.

## 4c: SANITATION

**Table S2. Comparison of sanitation options**

	<b>ADVANTAGES</b>	<b>DISADVANTAGES</b>
Sealed pit latrines	<ul style="list-style-type: none"> <li>■ Cheap</li> <li>■ Do not require water</li> <li>■ Do not require permanent superstructure</li> <li>■ Small land requirement on plot</li> <li>■ Control of flies and cockroaches providing that a tight fitting lid is placed over the hole in the slab</li> </ul>	<ul style="list-style-type: none"> <li>■ Excreta may be visible</li> <li>■ Possibility of smells</li> </ul>
Ventilated improved pit latrines	<ul style="list-style-type: none"> <li>■ Cheap</li> <li>■ Do not require water</li> <li>■ Control of flies</li> <li>■ Less smell in latrine</li> <li>■ Small land requirement on plot</li> </ul>	<ul style="list-style-type: none"> <li>■ Extra cost of vent pipe and superstructure</li> <li>■ Excreta may be visible</li> </ul>
Pour flush latrines	<ul style="list-style-type: none"> <li>■ Cheap</li> <li>■ Absence of smell in latrine</li> <li>■ Control of flies</li> <li>■ Contents of pit not visible</li> <li>■ Excellent from the user's point of view</li> </ul>	<ul style="list-style-type: none"> <li>■ Only suitable if water is used for anal cleansing</li> <li>■ Extra cost of pour flush bowl</li> <li>■ Requires reliable water supply</li> </ul>
Septic tanks	<ul style="list-style-type: none"> <li>■ Users have convenience of a conventional cistern flush toilet</li> </ul>	<ul style="list-style-type: none"> <li>■ High cost</li> <li>■ Reliable and ample water supply from house connection required</li> <li>■ Problems with effluent disposal</li> <li>■ Large land requirement for effluent disposal; unsuitable for high-density housing</li> </ul>



SERVICES FOR THE URBAN POOR

Table S2. continued		
	ADVANTAGES	DISADVANTAGES
Sewerage	<ul style="list-style-type: none"> <li>■ User convenience; no concern what happens after toilet is flushed</li> <li>■ Means of sullage disposal</li> <li>■ Usable with very high density housing</li> </ul>	<ul style="list-style-type: none"> <li>■ High construction and maintenance cost</li> <li>■ Efficient institutional organisation needed for construction, operation and maintenance</li> <li>■ High level of water supply service required (minimum about 70 litres per person per day)</li> <li>■ Only suitable if water or soft material is used for anal cleansing</li> <li>■ Adequate sewage treatment process is required before discharging to a water course</li> </ul>
Vault and cartage	Satisfactory for users if the collection service is reliable	<ul style="list-style-type: none"> <li>■ High construction and operation cost</li> <li>■ Highly efficient central organisation required to maintain regular collection service</li> <li>■ Serious health hazards if collection is inefficient</li> <li>■ Adequate sewage disposal facilities required</li> </ul>
Communal latrines	<ul style="list-style-type: none"> <li>■ May be the only option in highly congested sites with poor water supply</li> </ul>	<ul style="list-style-type: none"> <li>■ Lack of responsibility for funding and carrying out maintenance service.</li> <li>■ If maintenance is bad, latrines will not be used</li> <li>■ Inconvenient and undesirable for the user unless access is controlled</li> </ul>

---

## **Tool S2 Sanitation: Planning on-plot systems**

---

### **On plot sanitation systems**

The two most common types of on-plot sanitation are firstly pit latrines and secondly septic tanks; both require land to be set aside on or nearby the plot. The housing density, site layout, and the layout of individual house plots in respect of building lines and plot boundaries must be carefully considered when planning an on-plot excreta disposal system. Particularly important is the proximity of shallow wells. In general a minimum distance of 15 metres (other than in fractured geological formations) between a pit and a downstream well used for drinking purposes should be sufficient to prevent pollution of the water supply. If there is conflict between on-site sanitation provision and an on-site water supply it is usually cheaper to provide an off-site water supply than it is to move from on-plot to off-plot sanitation.

### **Pit latrines**

The principle of all types of pit latrine is that excreta and anal cleansing materials are deposited in a hole in the ground. In its simplest form, as illustrated in Figure S.2, the pit latrine consists of a superstructure which affords privacy to the user, a hole (or seat) set into a slab which covers the pit, and a pit beneath the slab into which excreta are deposited.

Pit latrines are not used in conjunction with conventional flush toilets (see ‘septic tanks’); therefore only a relatively small volume of water enters the pit. The pit itself is not sealed, and liquid is allowed to seep from the pit into the surrounding ground. Whilst in the pit, excreta undergoes complex biological and chemical reactions which result in its eventual decomposition into humus-like solids, water, and gases. Water seeps away through the sides of the pit, and gases escape to the atmosphere, leaving a solid residue in the pit. The important point to note is that because of the long storage time in the pit, disease-causing organisms (pathogens) are eventually killed; the decomposition proceeds slowly with time however, and it may be up to two years before the decomposed excreta can be handled without undue risk of contamination. Two problems with simple ‘unimproved’ pit latrines are due to the nuisance from smell and flies. Improvements have been devised which help to reduce these nuisances.

SERVICES FOR THE URBAN POOR

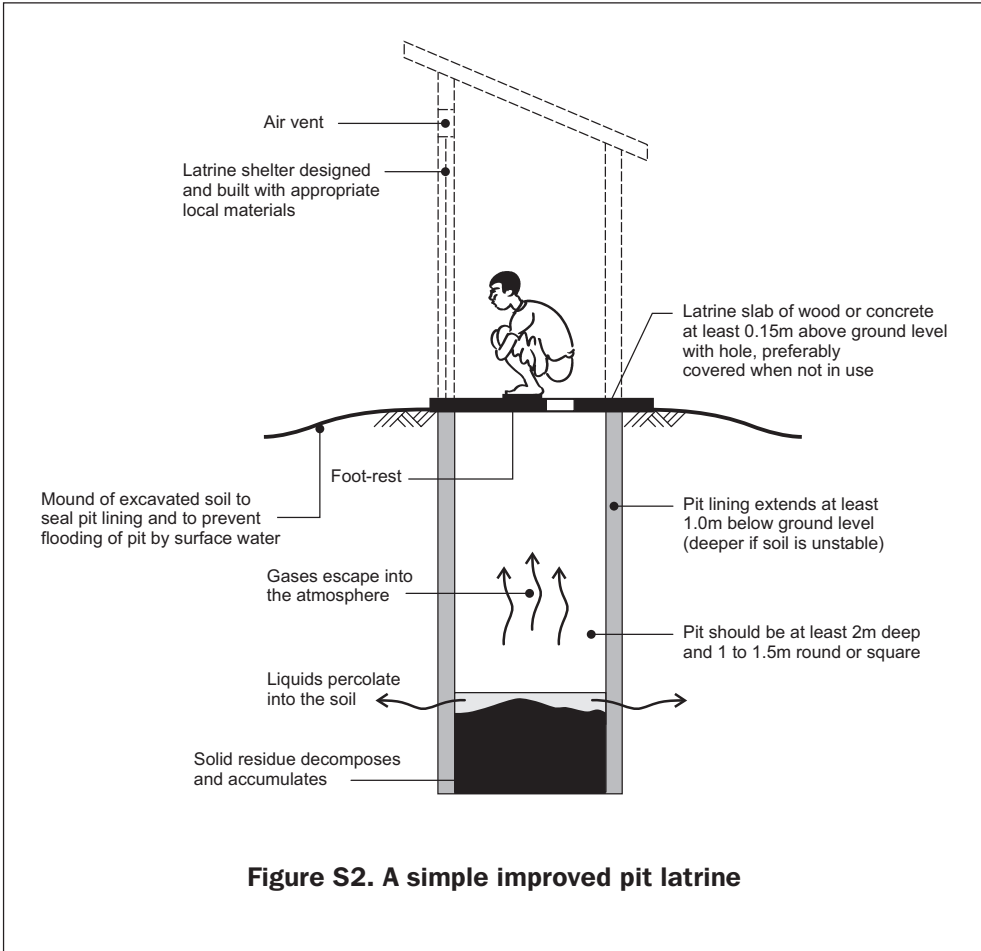

**Figure S2. A simple improved pit latrine**

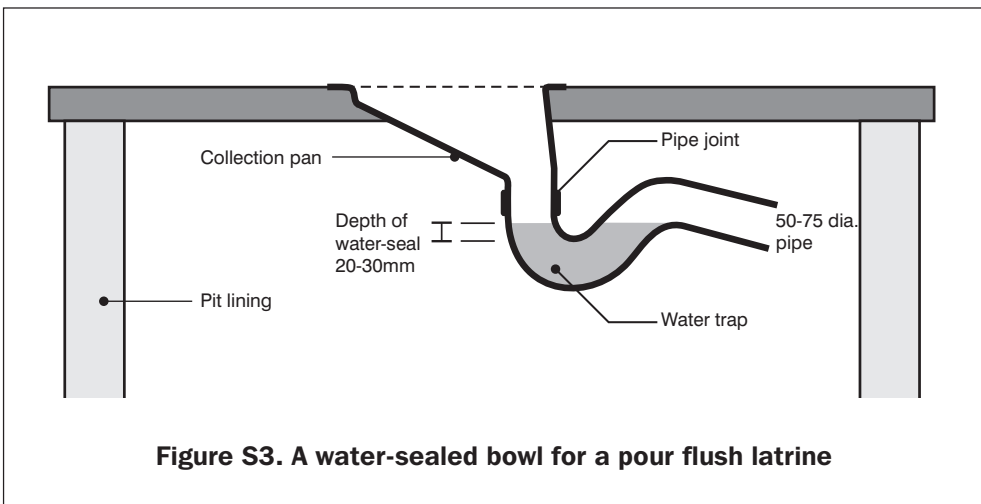

**Figure S3. A water-sealed bowl for a pour flush latrine**

### **Pour flush pit latrines**

In regions where water is used for anal cleansing, as opposed to solid material such as paper, leaves, stones or sand, it is possible to adapt the simple pit latrine by inserting a bowl into the hole in the pit cover slab as shown in Figure S3. When filled with water, this bowl forms an effective seal which isolates the pit from the user; this is a most effective way of eliminating smells and fly nuisance.

The bowl is designed so that it requires only a small volume of water to flush excreta into the pit. Depending upon the detailed design, 1-6 litres of water are required for each flush, which is much less than the 10-20 litres for conventional cistern flush toilets.

The pour flush latrine has great flexibility in its application. For example, the pit can be constructed to one side and connected to the slab by a short length of sewer pipe; this is known as an 'offset' pit latrine. Pour flush latrines are particularly useful in densely populated urban areas where access for pit emptying is restricted. With the pour flush latrine it is possible to locate the actual toilet in one part of the house whilst having the pit elsewhere. The latrine could be at the rear of the house with the pit at the front, as shown in Figure S4. Such an arrangement offers greater flexibility when planning the site layout and access.

A further modification is the double pit pour flush latrine described later in this tool.

SERVICES FOR THE URBAN POOR

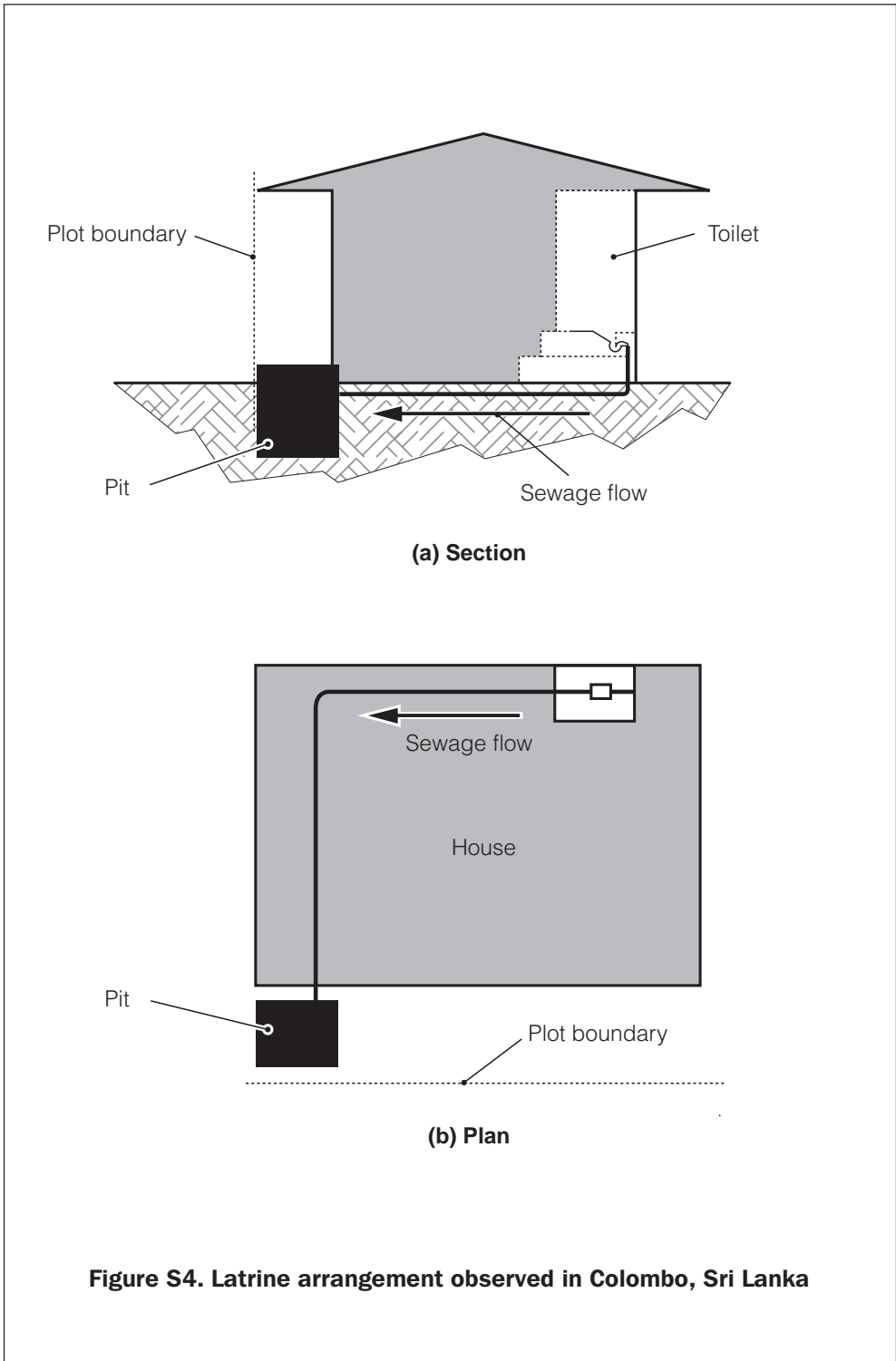

Figure S4. Latrine arrangement observed in Colombo, Sri Lanka

## **Other improved latrines**

### **Sealed lid pit latrines**

An improved low-cost latrine appropriate in areas of severe water shortage where the pour flush is not practical can be based on a design used in Mozambique. There is a tight-fitting lid of high quality concrete which fits into the hole in the latrine slab. This reduces the nuisance from odours and flies. In addition, a relatively cheap unreinforced dome-shaped concrete slab is used as shown in Figure S8. This is a cost effective and simple solution. The sealed lid pit latrine does not require water for its operation and there are no restrictions on the type of anal cleansing which can be used.

### **Ventilated improved pit latrines (VIPs)**

Another design appropriate for areas of water shortage is a latrine which is ventilated by means of a vertical pipe; the action of wind blowing over the top of the vent pipe creates an updraught of air which flows up the pipe. Air is drawn down through the hole in the cover slab and circulates in the pit; unpleasant odours pass up the pipe rather than out of the hole in the cover slab into the superstructure, as illustrated in Figure S9. Flies are attracted to the top of the vent pipe, but the presence of a fly screen made out of fine gauge mesh prevents many flies from entering. Flies which do breed in the pit tend to head towards light, but their exit is blocked by the screen. The interior of the latrine needs to be darkened, which requires the latrine to have a permanent superstructure with a roof. The VIP latrine does not require water for its operation and there are no restrictions on the type of anal cleansing which can be used.

Compared with the sealed pit latrine, VIPs are more expensive and this can make them unaffordable to poor sections of the community.

### **Problems caused by ground conditions**

Digging a pit is difficult when the ground is either extremely hard or extremely soft. Excavation in rocky conditions is expensive, and it is not normally feasible to dig deep pits. If the ground is totally impermeable, for example black cotton soil or hard rock, and there is no infiltration, another sanitation option must be selected.

Conversely with soft ground, such as running sand or alluvium, the excavation needs supporting and the sides of the pit must be lined down to the bottom as shown in Figures S5 and S6.

## SERVICES FOR THE URBAN POOR

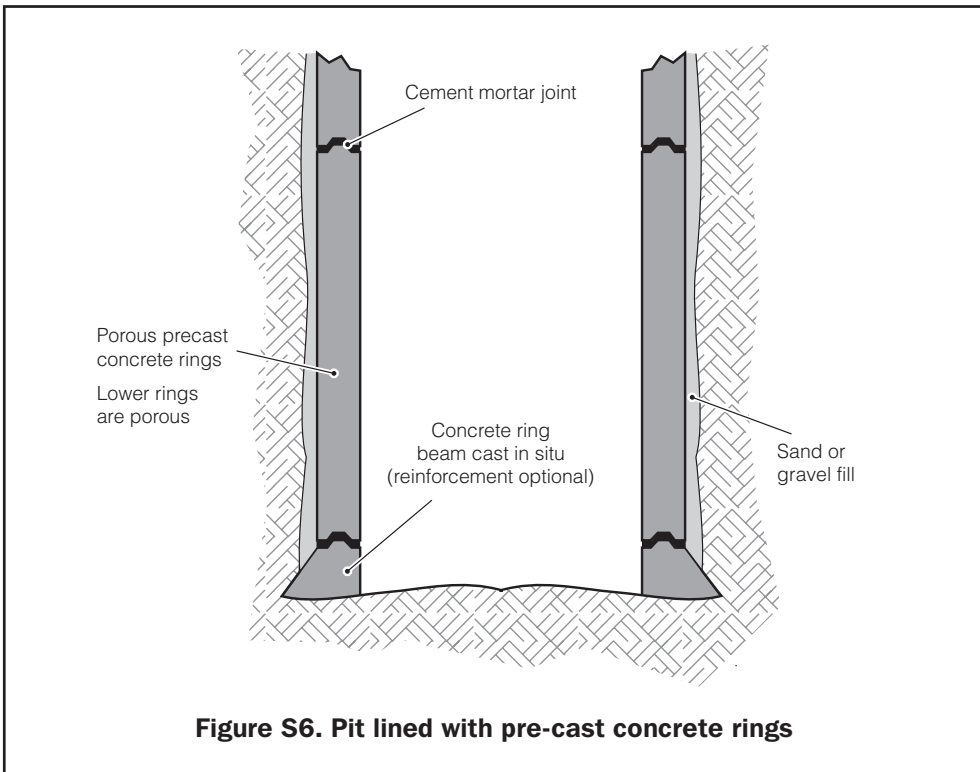
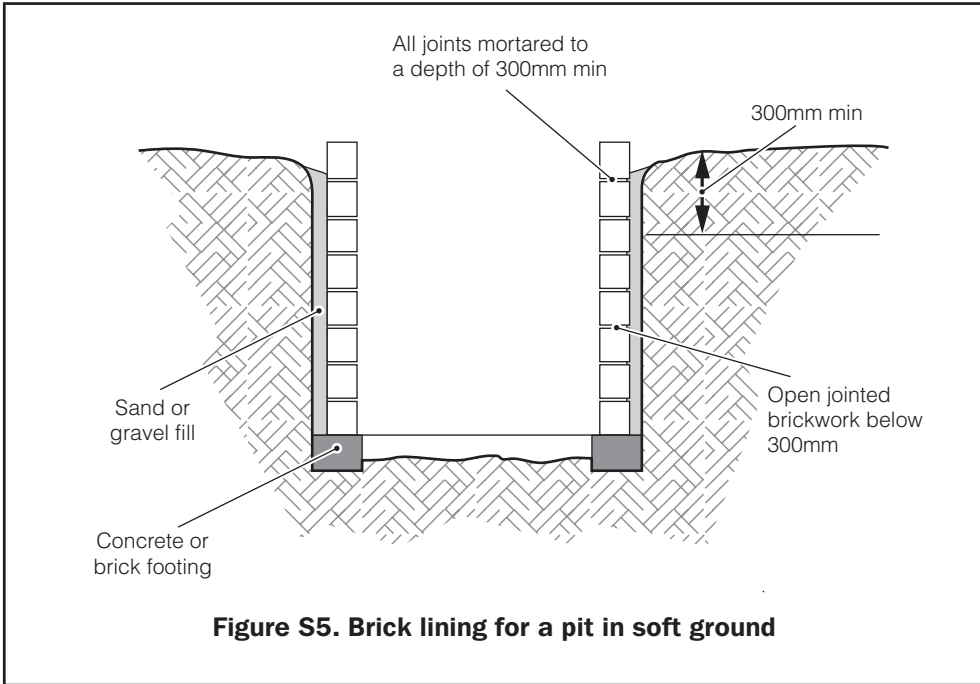

## **Problems caused by high water table**

Excavation is also made difficult by the presence of a high water table. The pit should be excavated in the dry season when the water table is at its lowest; in most situations it is not practical to dig more than about 1 metre below the water table.

The mere presence of water in the pit does not inhibit the functioning of the digestion process; the data in Table S3 shows that excreta decomposition is most effective in just these conditions. However, there are potential problems if pour flush latrines are used where the water table is high or the soil is relatively impermeable, and the housing density is high. Poor percolation may result in the ground near the pit becoming water logged.

For example, if each of six people in a household use 6 litres of water per day for flushing the latrine, the percolation rate through the ground surrounding the pit should be at least 36 litres per day. If this is not achievable, another sanitation option must be selected.

## **The groundwater pollution problem**

If the pit penetrates or is close to the groundwater table, water seeping out of the pit is bacterially and chemically contaminated and the surrounding groundwater may become polluted. This is particularly serious if shallow wells are located near to pit latrines. The extent of the pollution depends upon the soil conditions; the most dangerous case occurs in fissured rock, as the groundwater may travel rapidly through the fissures, transporting the pollution a considerable distance from the latrine. The travel of bacterial pollution through sandy soils is limited to a few metres; however, chemical pollution can travel further but the overall environmental health risks are less well demonstrated.

General guidelines are difficult to give because of the dependence on the specific ground conditions; pit latrines should always be downhill from a well and as far away as possible. A commonly used guideline in many soil conditions is to keep the bottom of the pit at least 2 metres above the water table and at least 15m from any well used for drinking purposes. Areas of high housing density have potentially high densities of pit latrines and there is a real danger of wells and pits being too close together. There is clearly an important interaction between the water supply and sanitation sectors and great care must be taken at the planning stage.



# SERVICES FOR THE URBAN POOR

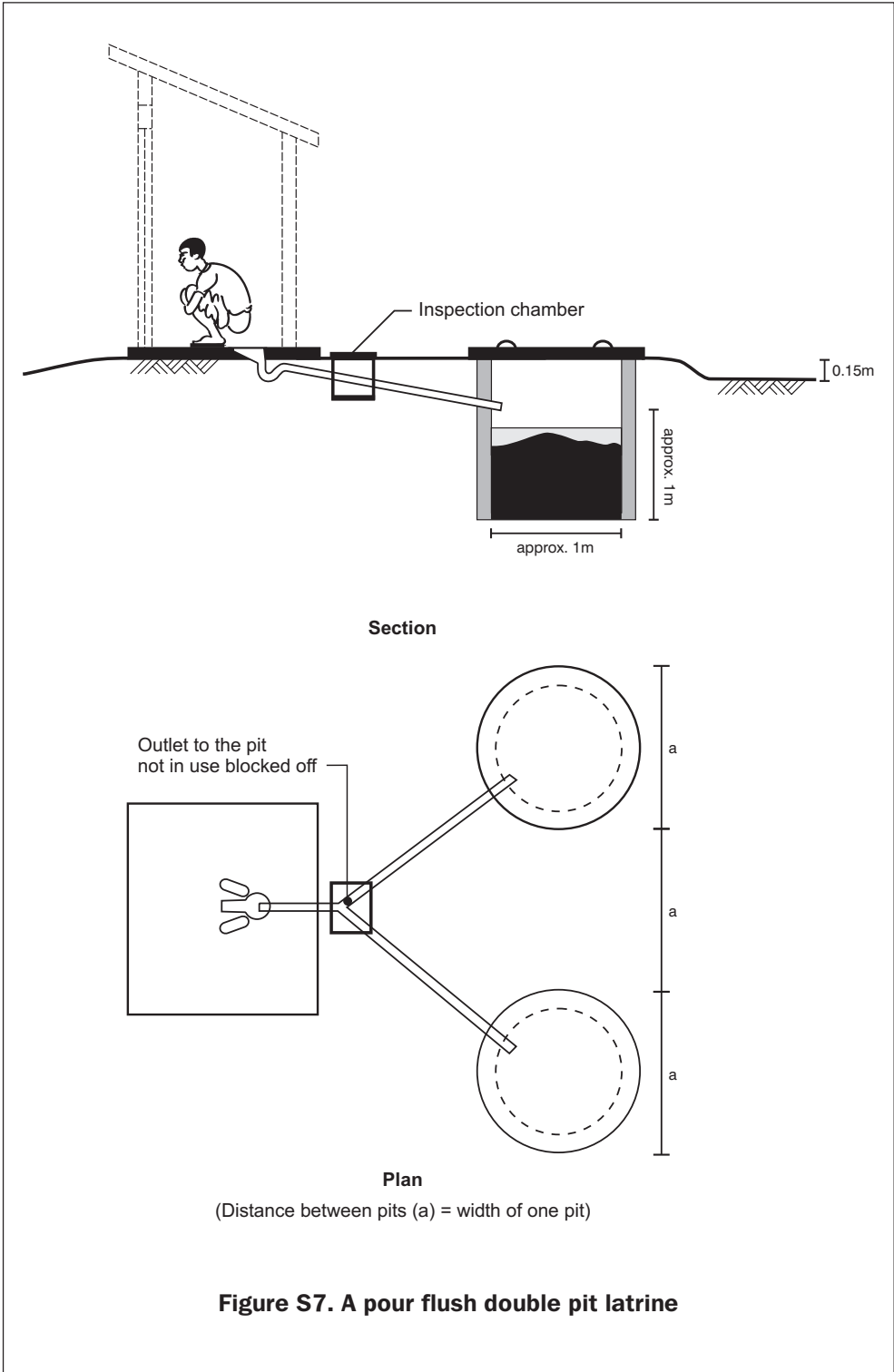

**Figure S7. A pour flush double pit latrine**

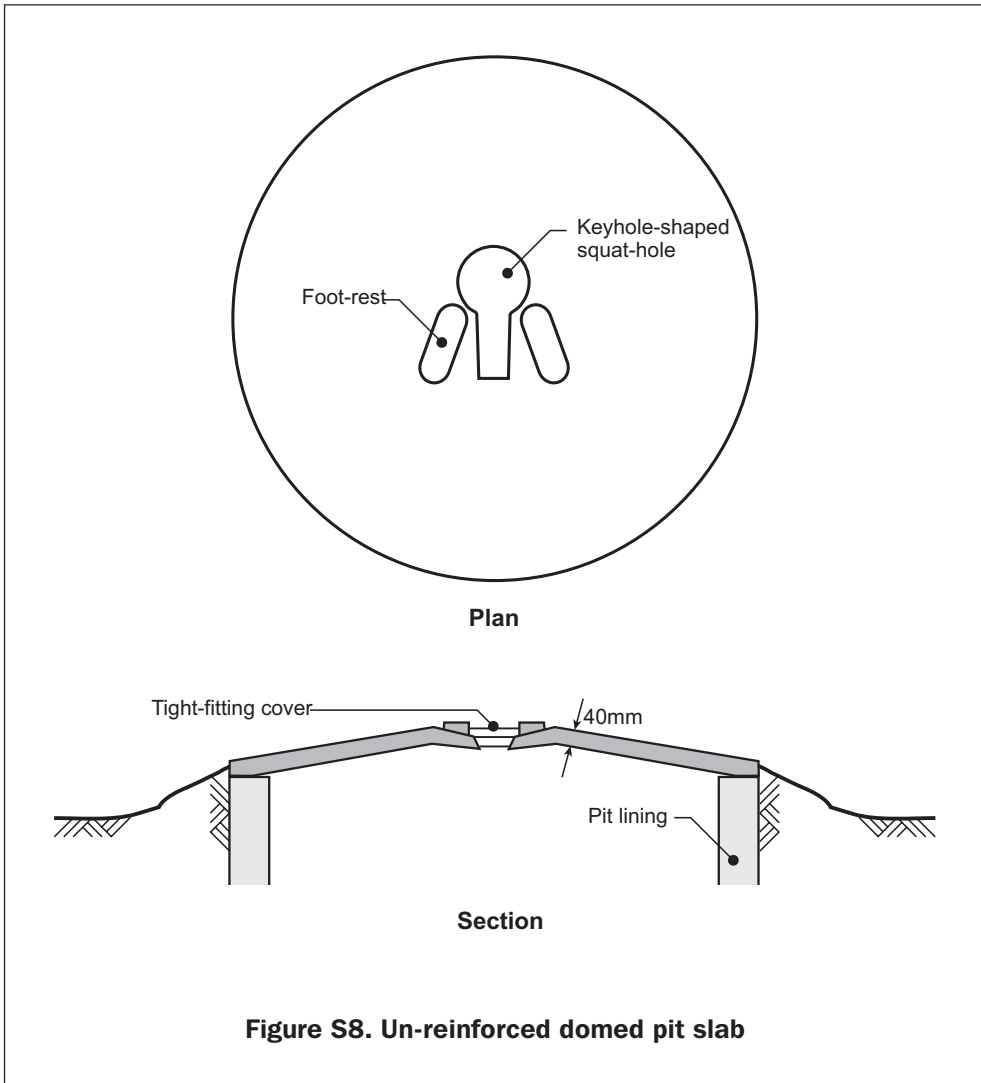

### Double pit latrines

The problems associated with ground conditions, high water table and groundwater pollution described above usually lead to the pit being very shallow. Unfortunately this means that the pit fills rapidly and regular emptying is required. Pit emptying can present a major health hazard; whilst excreta at the bottom of the pit is completely digested, the upper layer of the pit contents contains fresh excreta.

This difficulty can be overcome by using the double pit system in which both pits are shallow, but not less than 1.2 metres deep as illustrated in Figure S7; additional capacity can be obtained by increasing the plan area or raising the pit as described below, but this increases the cost. The capacity of each pit should be sufficient to ensure at least one year's use. The first pit is used until it is full, and the second pit is then put into use. When the second pit is full, the first can be emptied safely because the contents will have been digesting for at least one year.

Pour flush latrines with double pits have been used on a large scale in urban areas on the Indian subcontinent including in slum areas of high housing density which incorporate multi-storey buildings; if no land is available on the plot, the pits can be located beneath the access way.

### **Raised pit latrines**

In low lying areas which are prone to flooding, the whole latrine may need to be raised above existing ground level to avoid water completely filling the pit and bringing partly digested excreta up through the slab. Raising the pit provides a means both of increasing the capacity of the pit when excavation is difficult, thereby prolonging its useful life, and of overcoming difficulties with a high groundwater table. The raised portion of the pit above ground level should be lined and rendered so that it is impermeable, preventing the seepage of foul liquid out of the pit.

### **Septic tanks**

A septic tank comprises a sealed tank having both an inlet and an outlet into which excreta are flushed from a conventional cistern flush toilet using typically between 10 and 20 litres of water for each flush. The tank is usually connected to the toilet by a sewer pipe, and partially treated effluent flows out of the tank, as shown in Figure S10. This marks an important difference from the pit latrine, in which any water entering the pit leaves by percolation into the surrounding ground. Septic tanks may receive either toilet wastes alone, or both toilet wastes and sullage from sinks, showers and baths.

The volume of water entering a septic tank is large compared with the volume entering a pit latrine and it is assumed that each house has an individual water connection and cistern flush toilet. The septic tank acts as a settlement unit in which solids settle out by gravity; the solids undergo a process of anaerobic

#### 4c: SANITATION

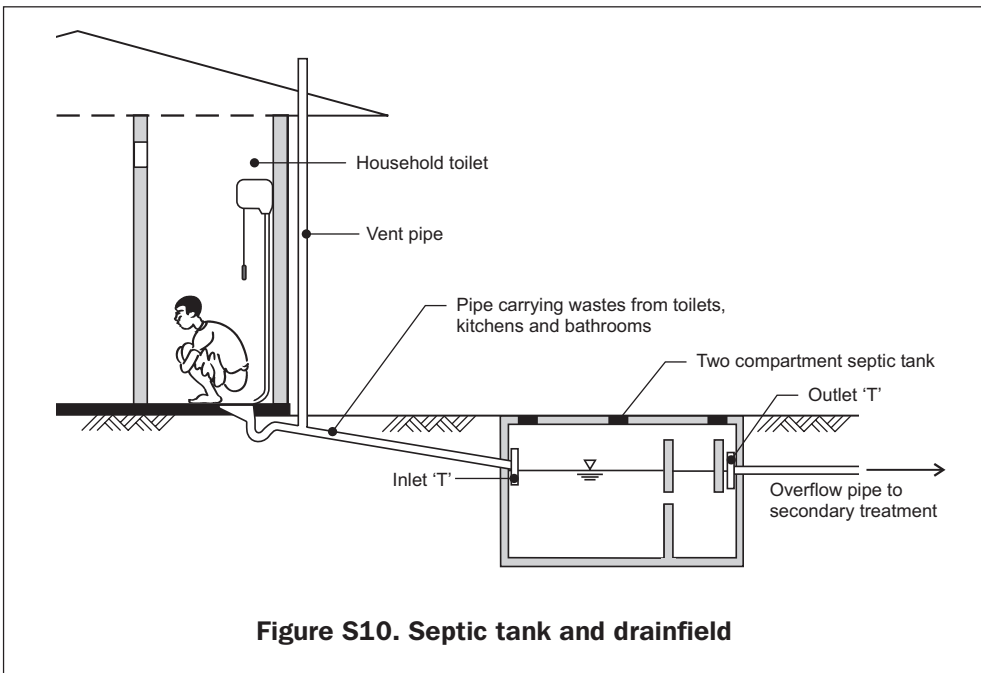
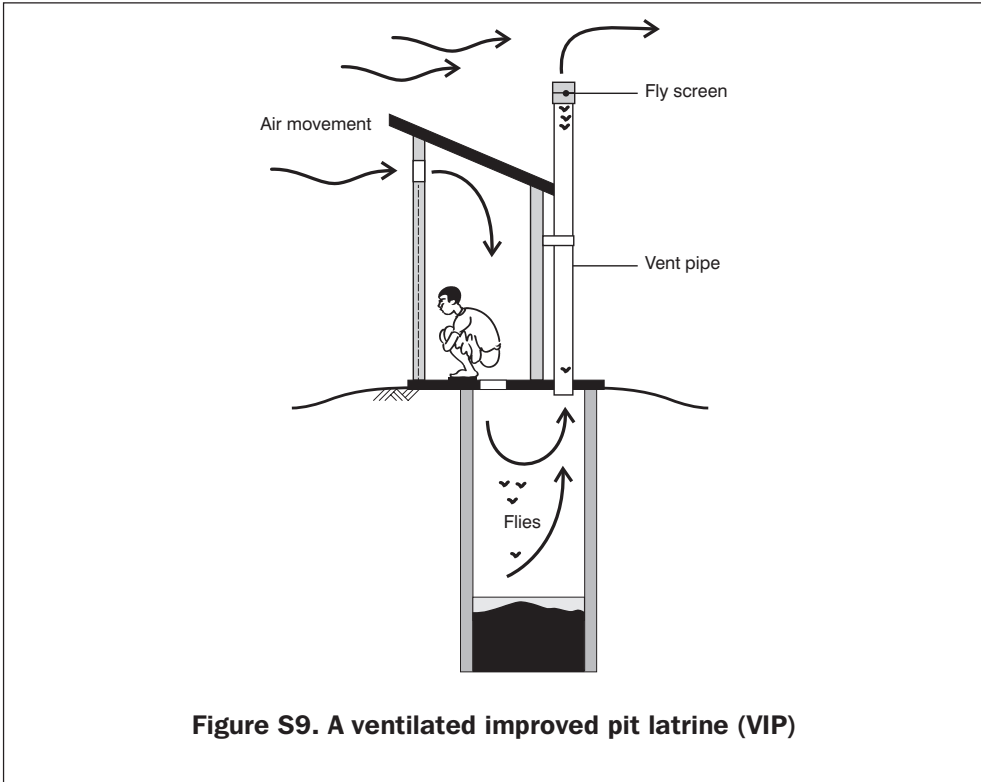

decomposition which results in the production of water, gases, sludge, and a layer of floating scum.

It is important to appreciate that the effluent which flows out of the septic tank constitutes a potential health hazard, and must be adequately disposed of. The residence time of the liquid in the tank is typically 1 to 3 days and many pathogens survive for longer than this.

The main problems usually arise from inadequate disposal of the tank effluent, which should not be allowed to run directly into the surface water drainage system. A common disposal method is by absorption into the ground using a soakage pit or trench. A large area of land is normally required because even when the ground is permeable, septic tank effluent only infiltrates very slowly. The land required for the soakaway is greater than for the septic tank and this limits the plot size and housing density for which septic tanks are a feasible option.

Given the problems of effluent disposal, it is normally better to allow only toilet wastes to be treated in the septic tank in order to reduce the volume of water to be handled by the soakaway.

Septic tanks may be used to provide primary treatment on a sewered site, or at communal latrines; the principal problem remains how to dispose safely of the tank effluent, because there is unlikely to be sufficient space for a soakaway in congested urban areas which have a high housing density.

---

## Tool S3 Sanitation: Design of on-plot systems

---

### Pit latrines

A pit latrine normally requires a piece of land not less than 1.5 metres square in order to accommodate the pit and superstructure. The latrine must be accessible so that the pit can be emptied when full. A latrine at the rear of a house should be accessible either from the rear of the plot boundary or from the front via an access way to the side of the building.

The rate of accumulation of solids in latrine pits in litres per person per year (l/py) depends upon the conditions in the pit. Approximate values are shown in Table S3.

Excreta under water in pit; degradable anal cleansing materials used, eg water, soft paper	40 l/py
Excreta under water in pit; non-degradable anal cleansing materials used, eg stones, heavy paper	60 l/py
Excreta in dry conditions in pit; degradable anal cleansing materials used	60 l/py
Excreta in dry conditions in pit; non-degradable anal cleansing materials used	90 l/py

These values are conservative and some measurements in wet pits suggest that the values could be halved.

The approximate time taken to fill a pit can be estimated using the data in Table S3. For example, consider a pit latrine having a pit which is 1 metre square in plan and 3 metres deep. It is used by a family of 6, and water is used for anal cleansing; the pit does not penetrate the groundwater table.

Pit volume = Plan area x useable depth

$$= [1.0 \times 1.0] \times [3 - 0.5] = 2.5 \text{ m}^3$$

= 2500 litres

The useable depth can be taken to be 0.5 metres less than the total pit depth.

Volume of solids = Number of users x Number of years x accumulation rate accumulated

$$2500 = 6 \times N \times 60$$

$$N = 6.9 \text{ years}$$

Thus the latrine can be used for about seven years before the pit needs to be emptied. In general, the pit should be dug as deep as is practicable in a given situation in order to minimise the frequency of pit emptying.

The diameter (for circular pits), or length of side (for rectangular pits), is normally about 1 metre. Circular pits are more stable because of the natural arching effect of the ground around the hole where there are no sharp corners to concentrate the stresses; however, people often find that rectangular holes are easier to dig.

In most cases, the walls of the pit require lining in order to support the excavation, unless the soil is self supporting. The top 300 mm to 500 mm of the pit should always be lined and sealed to support the slab and, where necessary, the superstructure.

Shallow pits up to 1.5 metres deep can almost always be excavated to their full depth and lined from the bottom up. The method of excavation of deep pits depends upon the stability of the soil during excavation; in soils that are not self-supporting, the pit lining must be constructed as the pit is dug. If the ground is very loose, 'caissoning' can be used. The pit lining is prefabricated above ground and placed in a starter excavation; soil is dug out from below and the lining sinks as the hole is dug, as illustrated in Figure S11. Any space around the outside of the pit lining should be backfilled with compacted earth taken from the pit, or, where available, with sand and gravel.

Pit linings can be constructed from:

- pre-cast rings of concrete or fired clay;
- brickwork, blockwork or stone;
- concrete which is cast in situ; and
- ferrocement.

In order to permit liquid to seep out of the pit into the surrounding ground, the pit lining must be porous. With brickwork, blockwork or local stone linings, a proportion of the vertical joints are left unmortared. If the ground is strong, a more open 'honeycomb' technique can be used. Concrete, ferrocement and fired clay ring linings are made porous by creating 25mm to 50mm diameter holes through the lining.

The latrine slab serves both as a support and a seal. It has to support the weight of the person using the latrine and possibly the weight of the superstructure, depending upon the design. It is also required to seal the pit.

Note that the type and design of the superstructure is entirely up to the individual and needs to meet their requirements for cost, privacy and status.

## **Septic tanks**

Many countries have Codes of Practice which govern the detailed design and construction of septic tanks; the following general procedure can be followed.

The first stage in septic tank design involves estimating the capacity required to retain the incoming sewage for a least 24 hours, and allowing additional capacity for the accumulation of sludge and scum.

Capacity for 24 hours sewage retention = PQ litres

Where

P = number of people served by the tank;

Q = sewage flow per person. This depends upon whether sullage enters the tank in addition to toilet wastes.

Capacity for sludge and scum accumulation = PNS



## SERVICES FOR THE URBAN POOR

Where  $N$  = number of years between desludging (usually between 2 and 5 years);

$S$  = 25 litres per person per year for toilet waste only, or 40 litres per person per year for sullage and toilet waste.

The minimum tank capacity is the sum of the capacities for liquid retention and sludge and scum accumulation. A typical arrangement is shown in Figure S12.

The size of soakage pit or trench required in permeable ground can be estimated by assuming an infiltration rate in the range 10-30 litres per day through each square metre of sidewall.

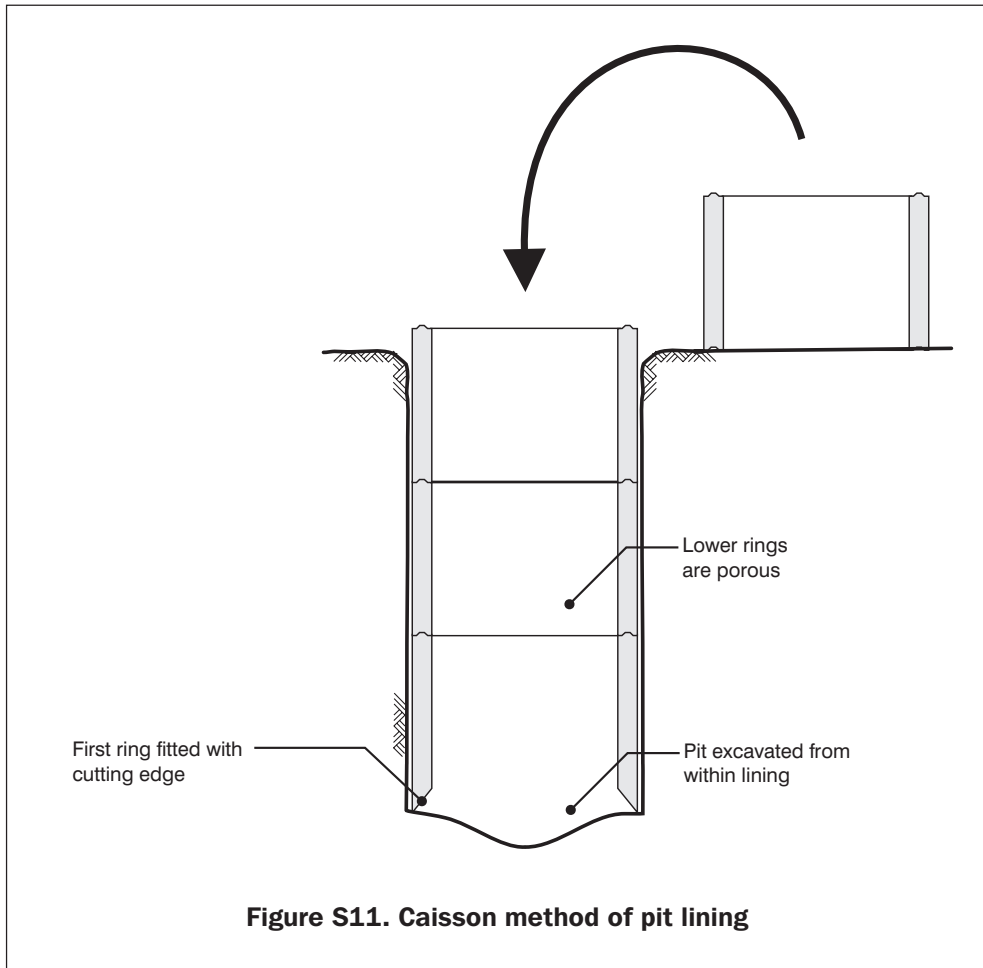

4c: SANITATION

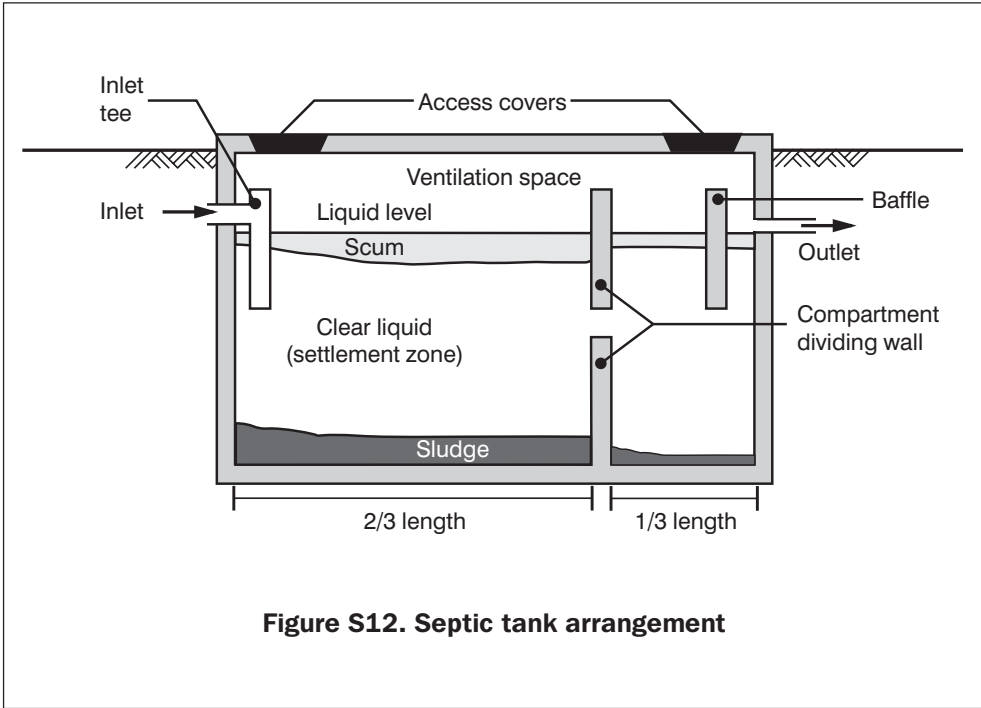

---

## **Tool S4 Sanitation: Sewerage planning**

---

### **About sewerage**

Water borne sewerage provides a means of removal of both excreta and sullage, which together are referred to as 'sewage'. It is very convenient from the users' point of view, and is widely used in many towns and cities of industrialised countries. The sewerage system comprises a network of buried pipes or sewers into which the sewage is discharged. Note that 'sewerage' refers to the network of sewers, and 'sewage' refers to the wastes that are carried in sewers. A large volume of water is required to carry the sewage solids along the sewers and to prevent their deposition. If the per capita water supply is less than 75 litres per day, sewers are unlikely to work satisfactorily. Only water or soft paper should be used for anal cleansing; sewers may block if bulky hard material is used. The sewers should deliver the sewage to a sewage treatment facility where suitable treatment processes render it safe for disposal into a river or the sea. It is important to note that the sewerage system itself is simply a means of removing excreta from one place and transferring it to another; it does not safely dispose of or treat the excreta.

If sewers are to be provided on low-income housing sites, they should discharge into an existing town or city main sewer that runs close to the site boundary. If land is cheaply available on the site, it may be feasible to provide a small sewage treatment facility such as waste stabilisation ponds. Sewerage is a relatively expensive sanitation option which requires a reliable piped-water supply.

### **Types of system**

The main type of sewer system is the 'separate system'. This is designed to carry foul flows only, i.e. flows from toilet, kitchen and bathroom areas, and is sometimes called 'foul sewerage'. Storm run-off from rainfall is collected in a system of drains which is completely separate. In practice, it is extremely difficult to exclude all storm flows from the foul sewers, and separate systems should always be designed with some allowance for stormwater flows.

Other systems include combined systems and interceptor tank systems.

A 'combined system' is designed to carry both foul and storm flows and thus removes the need for a separate storm drainage system. The problem is that the sewers, pumping stations and treatment works have to cope with extreme differences in flows because storm flows are so much larger than foul flows. Combined systems are rarely used in normal practice nowadays.

In an 'interceptor tank' system, solids are removed in interceptor tanks located on the sewer leading from the household toilet. It has the advantage that sewer sizes can be reduced and flatter slopes can be used because there is no need to transport solids. However, tanks must be regularly desludged, and there are few examples of this operating in practice.

## **Sewer networks**

A sewer system usually consists of a branched network of pipes similar to that shown in Figure S13. The pipes slope down towards the outfall and those furthest from the outfall are smallest. The pipes increase in diameter towards the outfall to cater for the increasing flows from incoming sewers. There is an important hierarchy in sewerage systems:

*Tertiary sewers* are those sewers at the neighbourhood level into which the individual house sewers discharge.

*Secondary sewers* are larger collector sewers into which the tertiary sewers from a particular area of the town or city discharge.

*Primary or trunk sewers* are large diameter sewers into which the secondary sewers discharge; they carry the sewage to the treatment works and outfall point.

The capacity of each part of the system has to be carefully matched. Whilst this may seem obvious when planning completely new systems, it becomes more complex when, for example, areas of the city are upgraded and new residential areas are developed. The new tertiary sewers need to discharge into existing secondary and primary sewers which may eventually result in the need to increase the capacity of the secondary and primary systems. This can be done either by pumping the sewage, or by laying new sewer lines in parallel to increase the capacity.

The fundamental principle of design is that wherever possible sewage should flow through the sewers by gravity. Normally sewage flows along sewers because they are laid with a slope (or 'gradient'). Where the ground has a natural slope, the depth of the sewers below ground level is often made constant. The sewers slope downhill towards treatment works which are located in low-lying areas.

Where land is flat, sewers get deeper to maintain a downward slope. Deep sewers are expensive and difficult to construct so it is sometimes necessary to raise the sewage by pumping, which:

- adds to the capital cost;
- introduces running costs for power; and
- is liable to failure because of plant breakdown, shortage of fuel or electricity failure.

The toilet, kitchen and washing/bathing areas should be connected to the sewer. In low-income housing areas it is neither appropriate nor likely that houses have large-volume cistern flush toilets; the maximum sewage flow is more likely to occur as a result of the house tap discharging rather than the toilet flushing.

### **Sewer layout**

The cost of sewerage depends on the length of the system and the depth of the sewers. In general, layouts should aim to minimise sewer lengths, providing that this does not result in increased depths. In practice, this means that sewers will normally follow topography as closely as possible with trunk and collector sewers laid along natural drainage routes.

### **Local (tertiary) sewers**

In order to determine the best layout, a plan of the area to be seweraged is required. If a survey is not available, a simple plan of the area should be prepared at a scale of 1:500, 1:1000 or their imperial equivalents. The route and levels of the nearest sewers to which sewers can be discharged (or drains if sewers are not available and temporary discharge to an existing drain is acceptable) should be shown. Levels should be provided at intersections, changes in slope and at any points that are obviously low-lying relative to surrounding areas.

4c: SANITATION

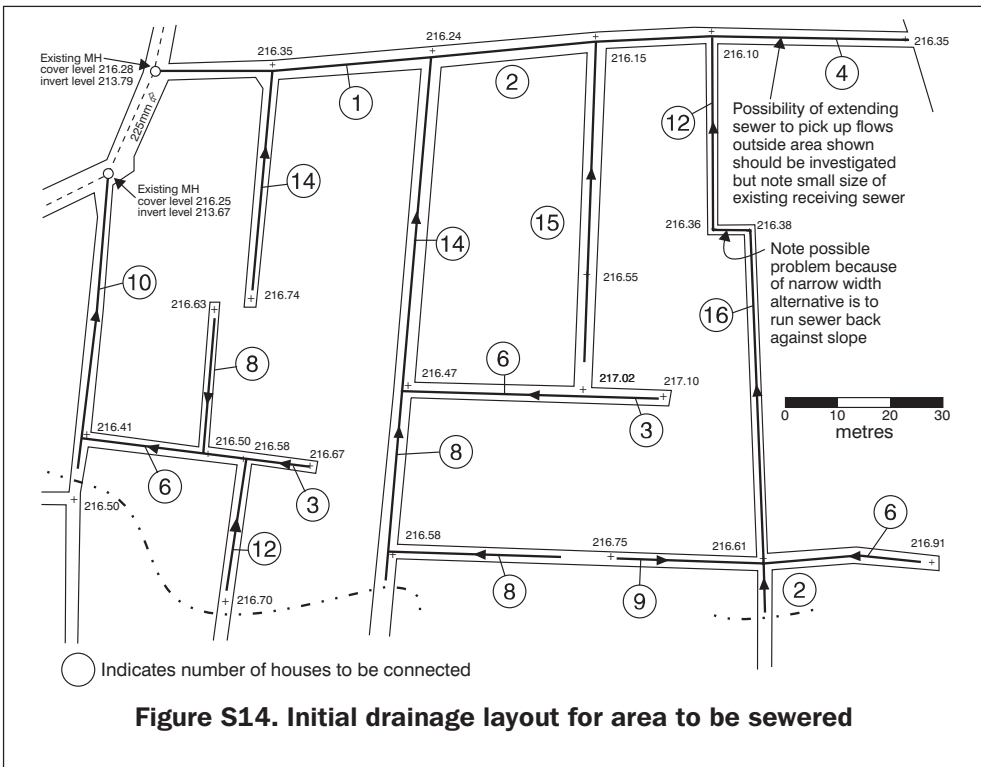
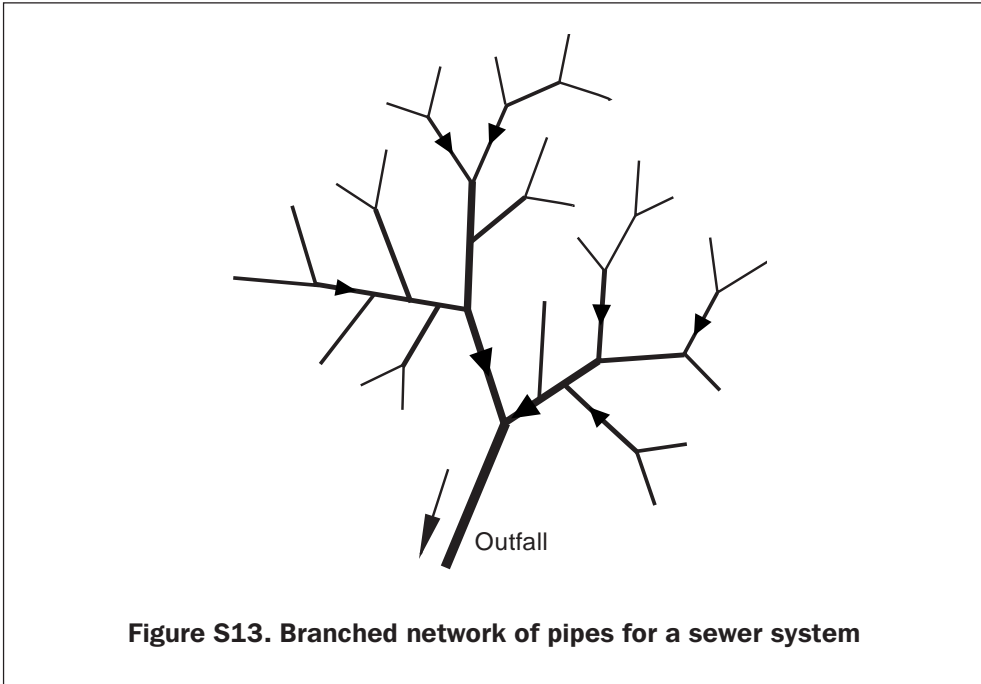

Once the plan has been prepared, the layout can be drawn on it. The best layout for local sewerage schemes connecting to existing collector sewers or drains will usually be fairly obvious with sewer routes following streets and lanes in most cases. In theory, there is the possibility of laying branch sewers serving a few houses through or behind plots but this is uncommon. The selected routes should follow the fall of the land except where there is little fall and a saving in overall length can be achieved by laying a sewer against the natural fall. Figure S14 shows a typical plan with sewer routes marked. Figure S15 shows how this basic plan can be developed to show the location of manholes. Figure S16 shows how this can be developed into a finished sewerage layout drawing.

### **Collector (primary and secondary) sewers**

For overall system design, the basic procedure is similar except that a plan scale of 1:2500 or even 1:5000 will be more appropriate. It will often be helpful to plot the routes of existing main drains and catchment area boundaries on the plan since it is likely that sewerage systems will have similar routes and catchment boundaries. Figure S17 shows the stages in developing the overall plan for a secondary sewerage system.

Pumping of sewage should be avoided wherever possible because it will increase running costs and the system will be liable to failure in the event of plant breakdown or power cuts. Where it is unavoidable, pumping facilities should be centralised as far as possible. Designers should avoid providing pumping stations in upgrading schemes unless the organisation to operate and maintain them exists.

### **Preparing plans for sewerage schemes**

Conventional practice for sewers is to provide a plan and longitudinal section for each length of sewer. For tertiary sewers, this is not necessary since all the required information on sewer routes, sizes, slopes and invert levels can be shown on layout plans. The invert level and cover level of each manhole should be shown, and the size and slope indicated against the sewers running between manholes. Where a branch sewer enters a manhole at a different level to the main sewer or there is a change in the main sewer invert at the manhole, this must be clearly indicated on the plan.

The manhole types required can be deduced from the cover and invert levels shown on the plan and the location. The type of each manhole should then be indicated on the plan. Figure S16 shows a typical finished sewer layout plan.

For small schemes constructed by municipalities and community groups, it may be possible to work on the basis of slopes rather than absolute levels provided that either:

- ground slopes are greater than about 1: 100; or
- the depth to the collector sewer which is to receive the flow is such that there will be no danger of the branch sewer being laid too low.

Standard details are required for each manhole type, typical house connections and pipe bedding arrangements. A schedule of trench widths may also be included with the drawings.

### **Decentralised sewerage**

In some situations where the city sewerage system is not extensive, it is possible to consider the feasibility of localised sewerage systems serving individual or neighbouring slums. Such a highly decentralised system raises important questions:

- what is the level of service for water supply?
- how will the system be operated and maintained?
- how should the collected sewage be treated prior to discharge to a receiving water?

If land is cheaply available on the site, it may be feasible to provide a small sewage treatment facility such as waste stabilisation ponds. However the required land area may not be available.

Local neighbourhood sewerage discharging into a communal septic tank (or interceptor tank) can be used to provide primary settlement for the sewage; this may have advantages on flat sites where sewers cannot be laid to a slope which is sufficiently steep to prevent solids being deposited. The interceptor tanks could be located at the housing cluster level to define the 'ownership' of the tank; this is of particular relevance to maintenance responsibility. There is little practical experience with this option.

There is some interest in a treatment process using upflow anaerobic sludge bed reactors (UASBs). They occupy relatively little land and the effluent quality (in terms of suspended solids, biochemical oxygen demand and chemical



## SERVICES FOR THE URBAN POOR

oxygen demand) is better than for septic tanks although the removal of pathogens (disease causing organisms) is not significantly different. *Neither provides effective pathogen removal, which is arguably the most important parameter from the environmental health point of view.* Basic engineering questions relating to construction materials and the management of operation and maintenance for these sludge beds remain unanswered.

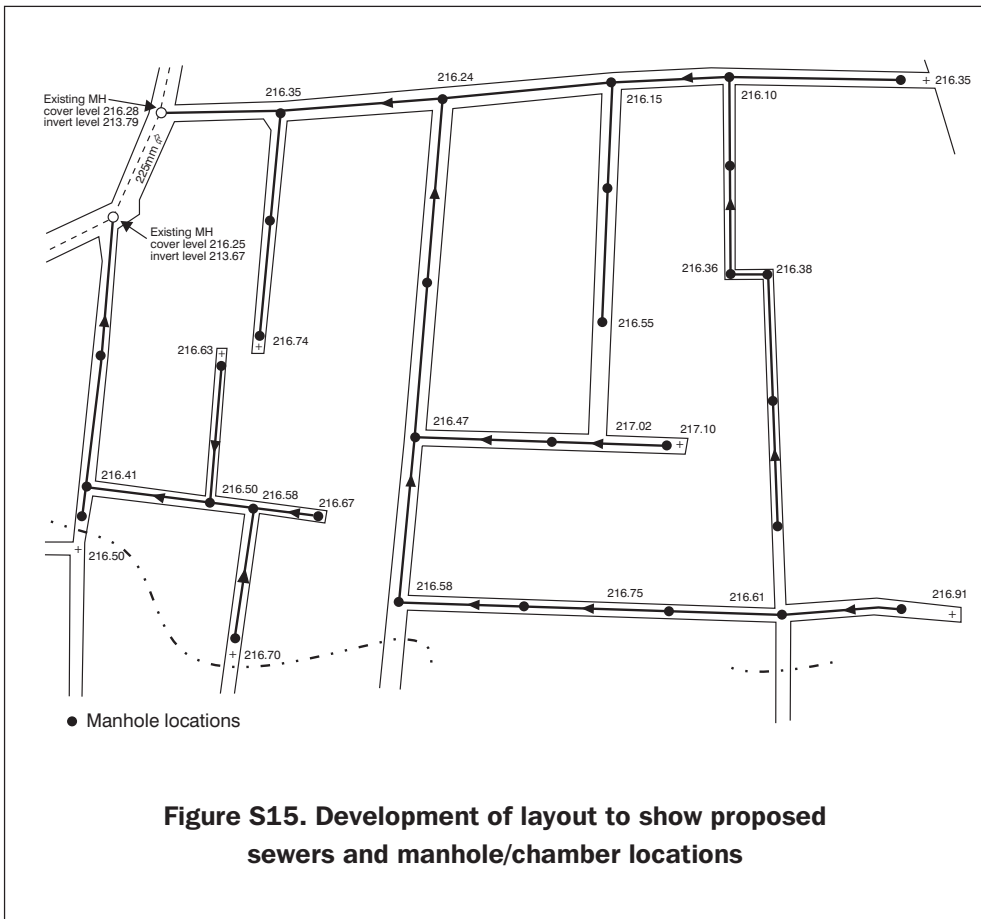

# 4c: SANITATION

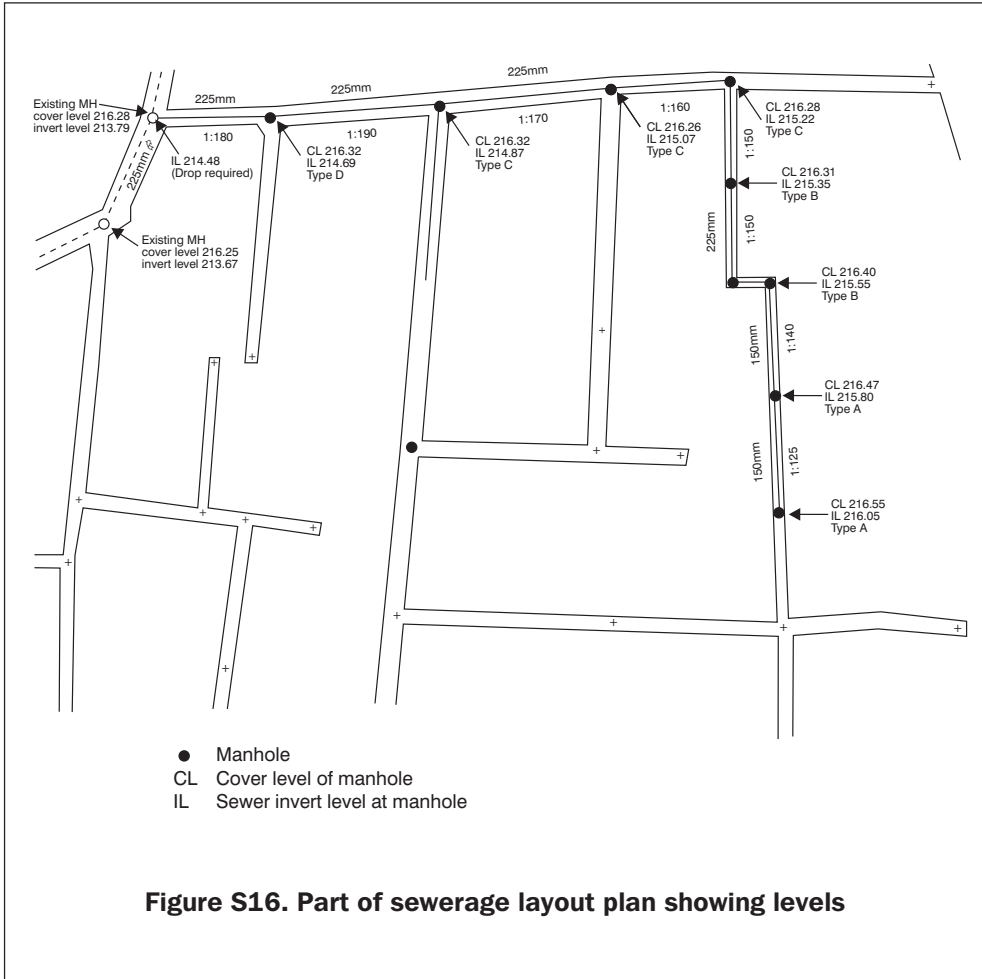

SERVICES FOR THE URBAN POOR

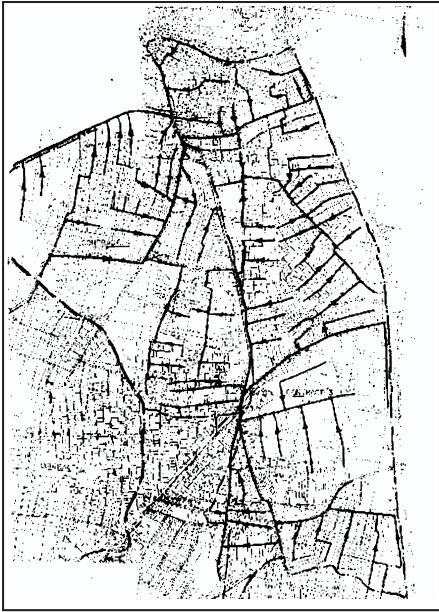

a: All existing drains and drainage boundaries plotted

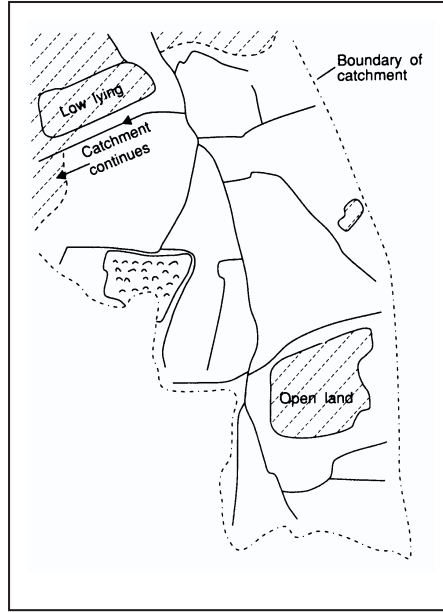

b: Main sewer routes identified

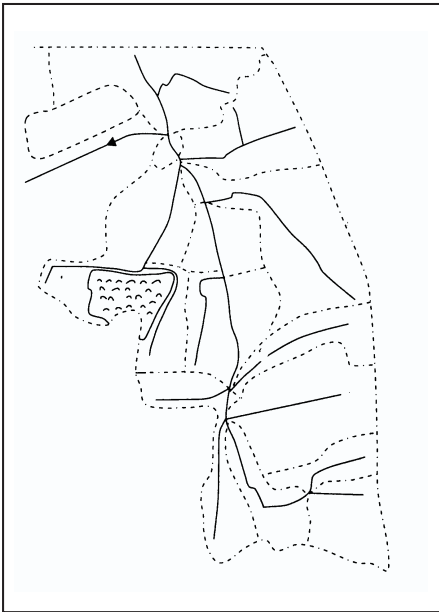

c: Catchment area sub-divided

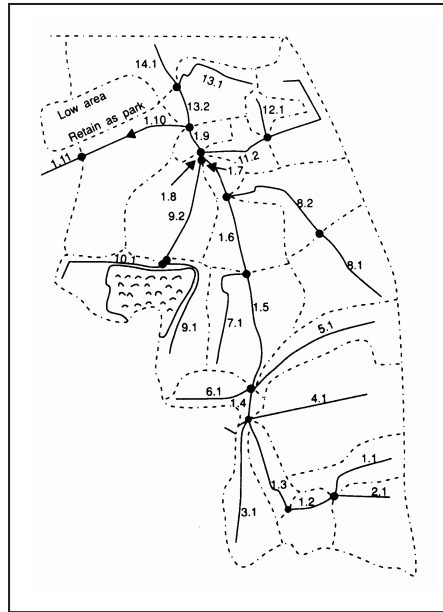

d: Sewer legs numbered

**Figure S17. Development of secondary sewer scheme for typical area**

---

## **Tool S5 Sanitation: Sewerage design**

---

### **Design objectives**

The detailed design of a sewerage system involves the determination of:

- the peak sewage flow which must be carried;
- the diameters of the sewer pipes and the gradients to which they are laid; both are related to the peak flow in the sewer;
- the design and location of manholes and other appurtenances; and
- specification of materials and construction methods.

For tertiary sewers, the design process is often simplified because the size of the sewer is governed by the minimum allowable diameter rather than the capacity required to carry the peak flow.

### **Conventional tertiary sewers**

#### **Number of houses served**

The calculation of peak flows in tertiary sewers can be related to the number of houses served. The number of houses contributing to each sewer length should be added to a copy of the layout plan as shown in Figure S14 (see Tool S4). The cumulative number of houses contributing at any point on the sewer can then be determined. All plots should be included, including those which are undeveloped.

#### **Design flow**

For all sewers, the design flow is the peak foul flow plus any allowance that is to be made for infiltration of groundwater and ingress of stormwater. Once the number of houses contributing to a sewer has been decided, the peak foul flow in the sewer can be calculated directly from an analysis of the probable frequencies and rates of discharge from WCs, washing areas, showers etc. converted into standard load units. The analysis is complicated and the results are normally presented in graph form. Figure S18 may be used to determine the likely peak flow for a sewer serving up to about 300 houses. It assumes a fairly high water use and the maximum level of on-plot facilities that will normally be found in low-income areas and is thus conservative.

Since almost all tertiary sewers will be laid above the water table, groundwater infiltration can usually be discounted. The allowance for storm water in nominally separate tertiary sewers can be taken to be equal to the peak foul flow, ie. the sewer should not run more than half full at the peak foul flow.

### **Determination of sewer diameter**

Using the maximum peak foul flow values given in Figure S18, assuming an equal allowance for storm water and using appropriate minimum sewer gradients, the following conclusions can be reached for nominally separate systems:

- a 100 mm sewer at a gradient of 1:150 will serve up to about 15 houses;
- a 150 mm sewer at a gradient of 1:175 will serve up to about 60 houses; and
- a 225 mm sewer at a gradient of 1 :210 will serve up to about 260 houses.

These figures assume that the sewers run freely without blockages. In practice, most sewerage authorities specify that the minimum diameter of public sewers should be either 150mm or 225mm. Many authorities require the larger diameter, arguing that smaller sizes will suffer frequently from blockages and are therefore unacceptable. While inspection confirms that sewers in low income areas are often partially blocked by silt and solid waste, there is no real evidence that 150mm diameter sewers require more maintenance than those of 225mm diameter.

The following *minimum standards* are suggested:

- single branch sewer serving up to 25 houses: 150mm dia.
- all other sewers: 225mm.

If these standards are adopted, the sizes of the vast majority of tertiary sewers can be determined on the basis of minimum diameter standards rather than the peak design flow.

The procedure for combined sewers is first to determine the gradient as for a nominally separate sewer and then to calculate the size of sewer required to carry the combined flow at this gradient.

### Sewer gradient

The sewer gradient should be the greater of:

- the minimum allowable gradient; and
- the slope available to maintain minimum cover. (This will usually approximate to the ground slope but may sometimes be influenced by the minimum allowable cover over the sewer).

In steeply sloping areas, it may also be appropriate to specify a maximum sewer gradient and provide drop manholes where this is less than the ground slope. For drops up to about 1m, it is probably unnecessary to provide a piped drop, particularly when the only materials available with which to construct the drop are expensive cast-iron pipes.

**Minimum gradients** The gradients of conventional separate and combined sewers must be sufficient to ensure that solids do not settle permanently. Figure S19 gives the suggested relationship between sewer slope and number of houses contributing for tertiary sewers. Once the layout has been decided and the number of houses on each sewer leg counted, as previously described, the minimum allowable gradient for each sewer length can be obtained from this figure.

**Maximum gradients** It has been traditionally assumed that flow velocities in sewers should be limited in order to prevent wear of the sewer invert. Recent research suggests that such restrictions are not necessary but this may not be true in informal areas where large quantities of grit are carried in sewers. It is therefore advisable to restrict maximum velocities in sewers to 2.5 m/sec, giving the following maximum gradients for the sizes commonly used for tertiary sewers:

Sewer diameter (mm)	Maximum gradient
100	1:5
150	1:9
225	1:15

SERVICES FOR THE URBAN POOR

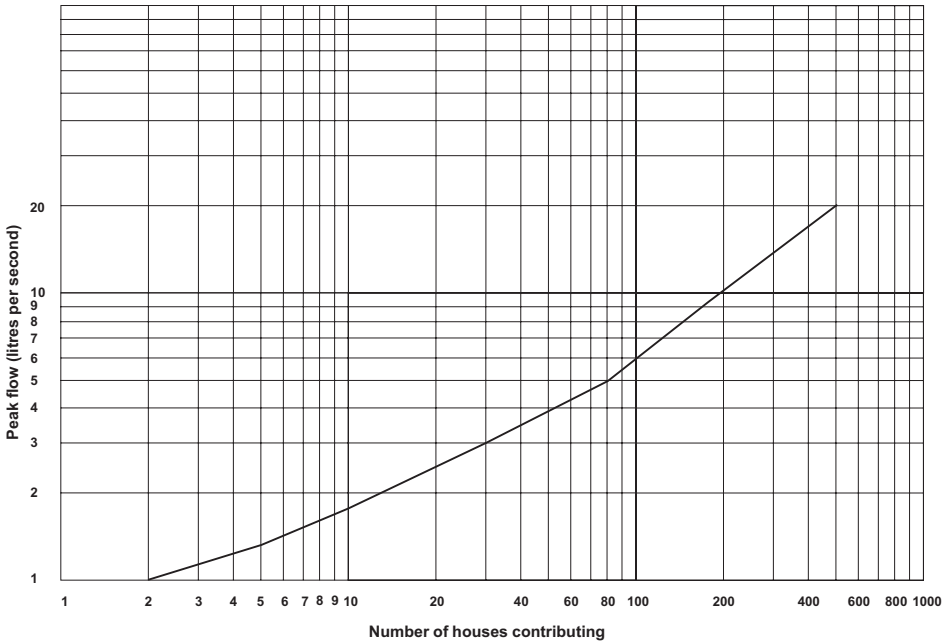

**Figure S18. Peak foul flow related to number of houses served for tertiary sewers**

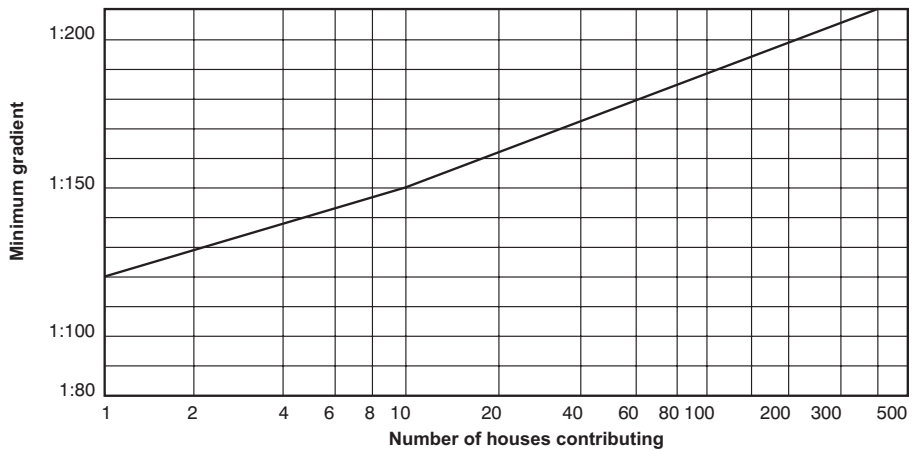

**Figure S19. Relationship between minimum sewer slope and number of houses served for tertiary sewers**

## **Primary/secondary systems**

The procedure for the design of primary and secondary sewers is briefly described here with attention focused on those aspects which assume particular importance in informal areas.

### **Determination of catchment areas**

The catchment areas for primary/secondary sewers can be determined in the light of the sewer routes, the topography and the planned extent of the tertiary sewers draining to the system.

Once the catchment boundaries have been fixed, nodes should be located on a plan of the system at all junctions between primary/secondary sewers and at further intervals as required to ensure that sewer legs between nodes drain between 3 and 10ha. The areas of these subcatchments are then calculated and the sewer legs are numbered, starting at the head of the longest sewer run, as shown on Figure S20. Figure S17 (see Tool S4) shows the stages in determining main sewer routes, catchment boundaries, node locations and catchment subdivisions for an area in North-East Lahore.

### **Calculation of design populations**

The population of each sub-catchment must now be calculated. For areas which are already substantially developed, this should be based on average population density figures. These are obtained by multiplying housing densities for typical areas obtained from analysis of plans by average household sizes based on the analysis of social surveys. Calculations for the former should include presently undeveloped plots while some increase in the latter with time may be assumed. An allowance of 10-20% growth in average household size over a 30 year design period will usually be appropriate.

For urban fringe areas and others in which development is still occurring rapidly, it may be appropriate to estimate future design populations by projecting forward existing population figures, using the expected annual percentage rate of growth. However, care should be taken to ensure that this procedure does not give future population densities that are unrealistically high.

### **Calculation of design flow**

The design flow for conventional separate systems is obtained by calculating the average dry weather flow (DWF) and then applying a factor, typically 6, to obtain the design flow. The factor allows for both peaks in the DWF and some ingress of stormwater. Thus, the sewer capacity can be related directly to the



SERVICES FOR THE URBAN POOR

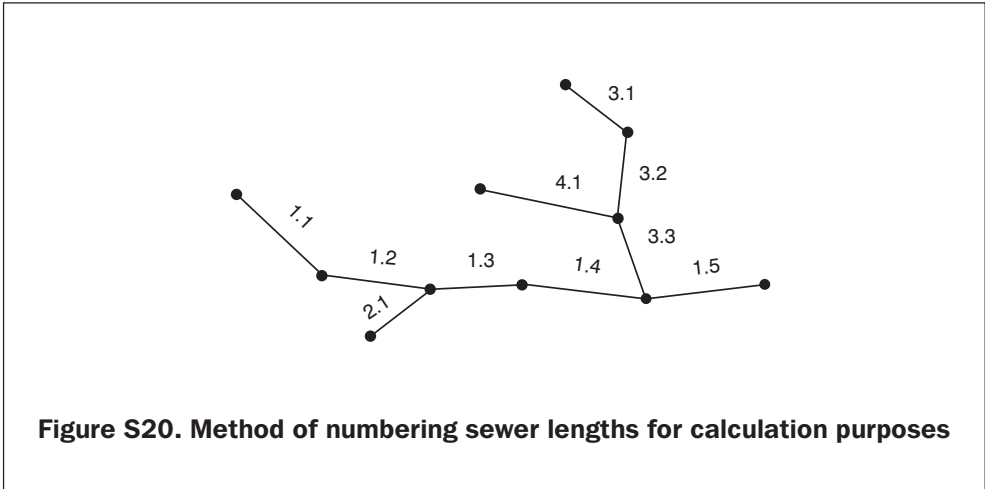

Figure S20. Method of numbering sewer lengths for calculation purposes

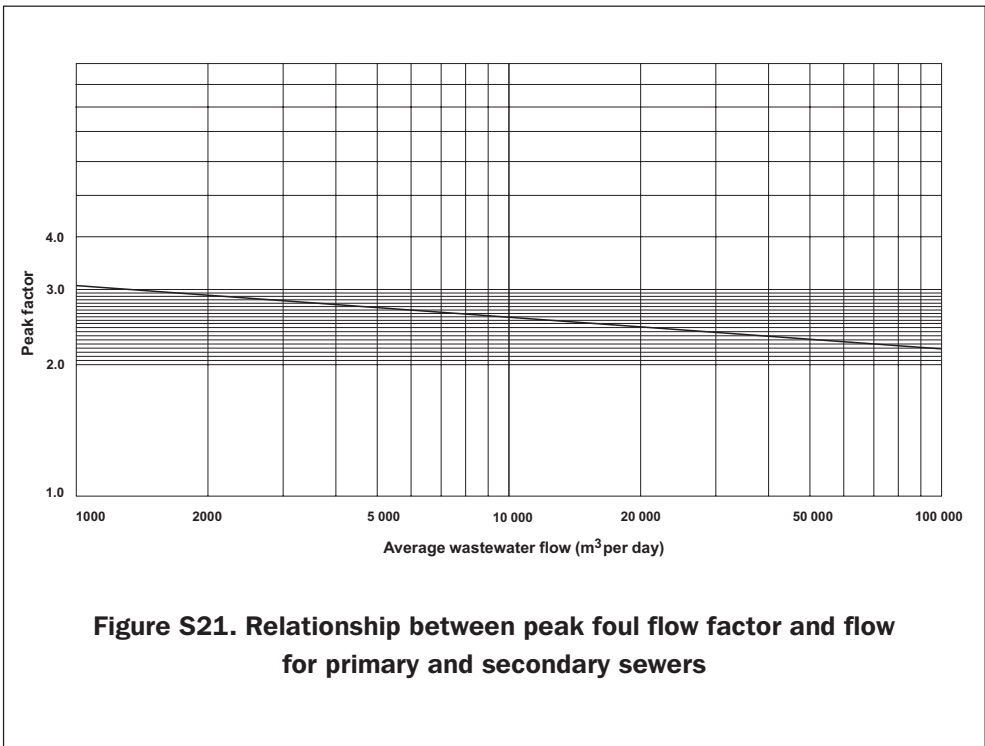

Figure S21. Relationship between peak foul flow factor and flow for primary and secondary sewers

design flow. The DWF in residential areas is related to:

- the design population; and
- the per-capita water consumption;

For informal housing areas, where per-capita water consumptions in areas with house connections will usually be in the range 75- 150 lpd, the average sewage flow can be taken as 80% of the average water consumption. (The water supply figure should exclude leakage but include on-plot wastage). Conventional sewers will not normally be appropriate for areas served by public standposts.

Additional allowance will have to be made for any industrial and institutional flows but these will not normally be significant in residential areas. Where relatively large industries or institutional discharges occur within the design area, specific allowance for them should be made in calculations.

The minimum sewer slope, however, should be calculated on the basis of the peak foul flow. Suitable peak factors for calculating peak foul flows for larger sewers can be obtained from Figure S21.

### **Determination of sewer gradients**

As for tertiary sewers, the sewer gradients adopted for primary/secondary sewers will normally be the greater of the ground slope and the minimum gradient required to prevent settlement of solids. Figure S22 should be used to obtain a preliminary estimate of minimum slopes for primary and secondary sewers. It relates design flow to sewer slope and also indicates the maximum flows that can be carried by different sewer diameters at the given minimum slopes.

Sewer gradients should not exceed the following values:

<b>Diameter (mm)</b>	<b>Maximum gradient</b>
225	1:15
300	1:22
375	1:30
450	1:39
525	1:47
600	1:57

Gradients may also be influenced by the minimum allowable cover over the sewer which will be considered later in the section on design standards.

### **Determination of sewer diameter**

The sewer diameter must be sufficient to provide enough capacity for the design flow at the design gradient. The simplest method for calculating sewer capacities is based on Manning's formula which states that:

$$V = \frac{R^{2/3} S^{1/2}}{n}$$

where V is the flow velocity; R is the hydraulic radius (d/4); S is the hydraulic gradient; and n is Mannings roughness coefficient.

An 'n' value of 0.015 should be used. For primary/secondary sewers, V should not be less than 0.7m/sec. Figure S22 may be used to obtain an initial estimate of the required sewer diameter. Detailed calculations should follow using standard calculation sheets similar to that for stormwater drainage calculations.

### **Invert levels and manhole types**

Sewer sizes and gradients are normally calculated between points at which manholes will be located. Invert levels at these points are calculated in the course of the detailed design and entered on to standard calculation sheets. The invert levels at intermediate manholes can then be worked out by interpolation but the depth should be checked in each case to ensure that minimum depth standards are not being broken. Once the invert levels and manhole depths have been obtained, the appropriate manhole design can be chosen using the criteria given later in this chapter. Figure S16 (see Tool S4) gives details of the way in which cover and invert levels, sewer diameters and gradients can be presented for tertiary sewers. For primary and secondary sewers, the information will normally be provided as a plan and section.

4c: SANITATION

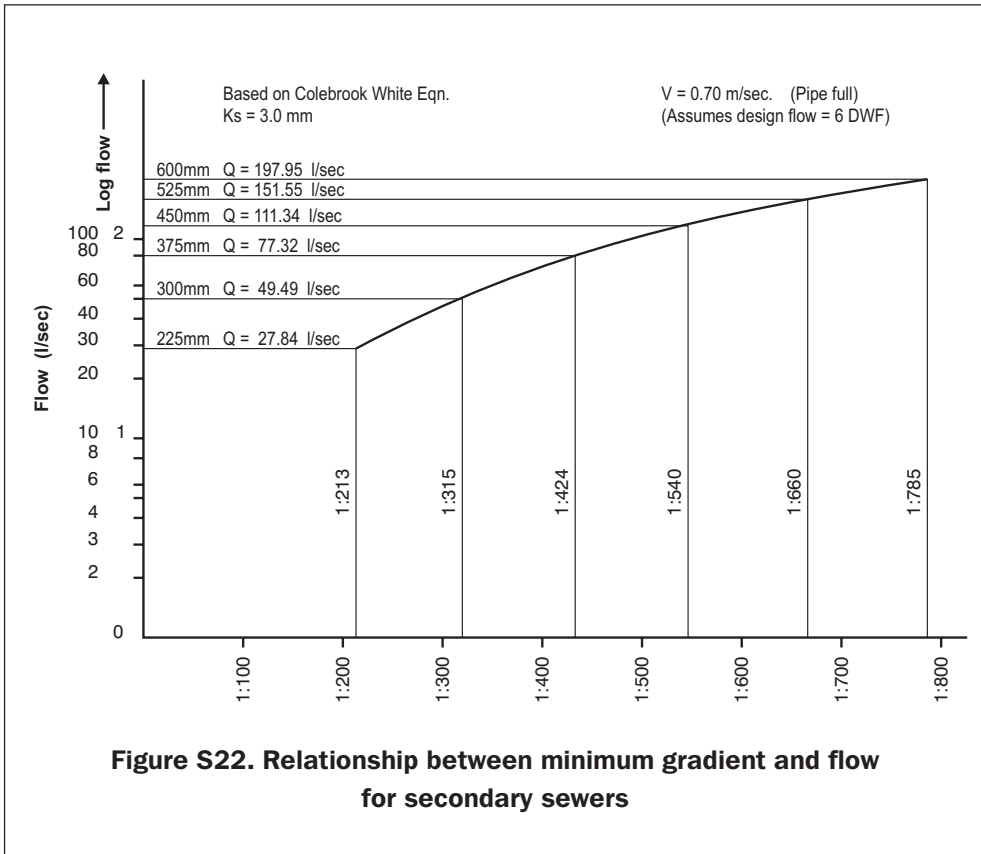

## **Design standards and details**

### **Minimum cover**

The minimum permissible cover is an important factor in determining the depth of sewers throughout their lengths. Reduced sewer depths mean lower costs, partly because of reduced excavation but, perhaps more importantly, because of the smaller manholes that can be used on shallow sewers. Design criteria for manholes on shallow sewers will be given later.

Minimum cover standards should take into account both the traffic loading and the strength of the pipe. For local streets, the likely traffic loading can be related to the width of the street. Bearing these points in mind, Table S4 gives recommended minimum cover standards for the concrete sewer pipes commonly used in Pakistan.

The above figures are based on extensive field experience in Lahore and Peshawar. It should be noted that rights of way are invariably less than street widths because of obstructions such as house access steps and electricity poles. The covers provided over clay and plastic sewer pipes should be at least 500mm unless some protection, in the form of a concrete bed and surround, is provided to the pipe.

The standards given in Table S4 are those required for structural purposes. Sewers must also be deep enough to allow house connections to be made. As a general rule, the minimum depth to sewer invert for connections of 5 metres length and less should be 500mm with an additional 100 mm allowed for every additional 5 metres length of connection.

Cover over 100 mm concrete pipes can be less. In non-vehicular streets, house connections are often laid with virtually no cover. As a general rule, the covers allowed on 100 mm concrete pipes should not be less than two-thirds of those given in Table S4.

Some reduction in cover is possible if a sewer is bedded and surrounded with concrete. This will normally only be economic for short lengths at the heads of those sewers whose levels have an effect on levels throughout the whole system.

**Table S4. Minimum cover standards for 150mm and 225mm dia. concrete sewers**

Street width	Heaviest vehicle	Recommended minimum cover
>3m	Motorcycle	250mm
3 - 4.5m	Suzuki car or van	350mm
4.5m	Cars, horse drawn carts etc.	400mm
>6 residential	Occasional trucks	500mm
Main roads	Heavy goods vehicles	800mm

### Manhole and chamber dimensions

Manholes and chambers are intended:

- to allow drainage rods to be pushed into the sewer to clear blockages; and
- to allow access to the sewer so that unwanted material can be removed.

Manholes are designed to be entered to achieve these tasks. Inspection chambers are used on sewers which are shallow enough for the invert to be reached without entering the chamber. Suggested minimum plan dimensions for manholes and chambers are given in Table S5. The term ‘partial entry’ used in the table means that a man will have to stand on the benching in the manhole with his upper body above ground level.

Some typical details for small manholes are given in Figure S23.

### Manhole location and spacing

Accepted standards require that manholes are placed at all junctions, and changes in direction, gradient and size and at intervals that allow the sewer to be rodded or otherwise cleaned. For primary and secondary sewers, manhole spacing should not exceed about 90 metres and for tertiary sewers, 50 metres. Even this may be too great if proper drain rods with screw-in connections are not available. (The common practice in many towns at present is to tie bamboo rods together with wire. Such rods have been tested between manholes spaced 25 metres apart).

SERVICES FOR THE URBAN POOR

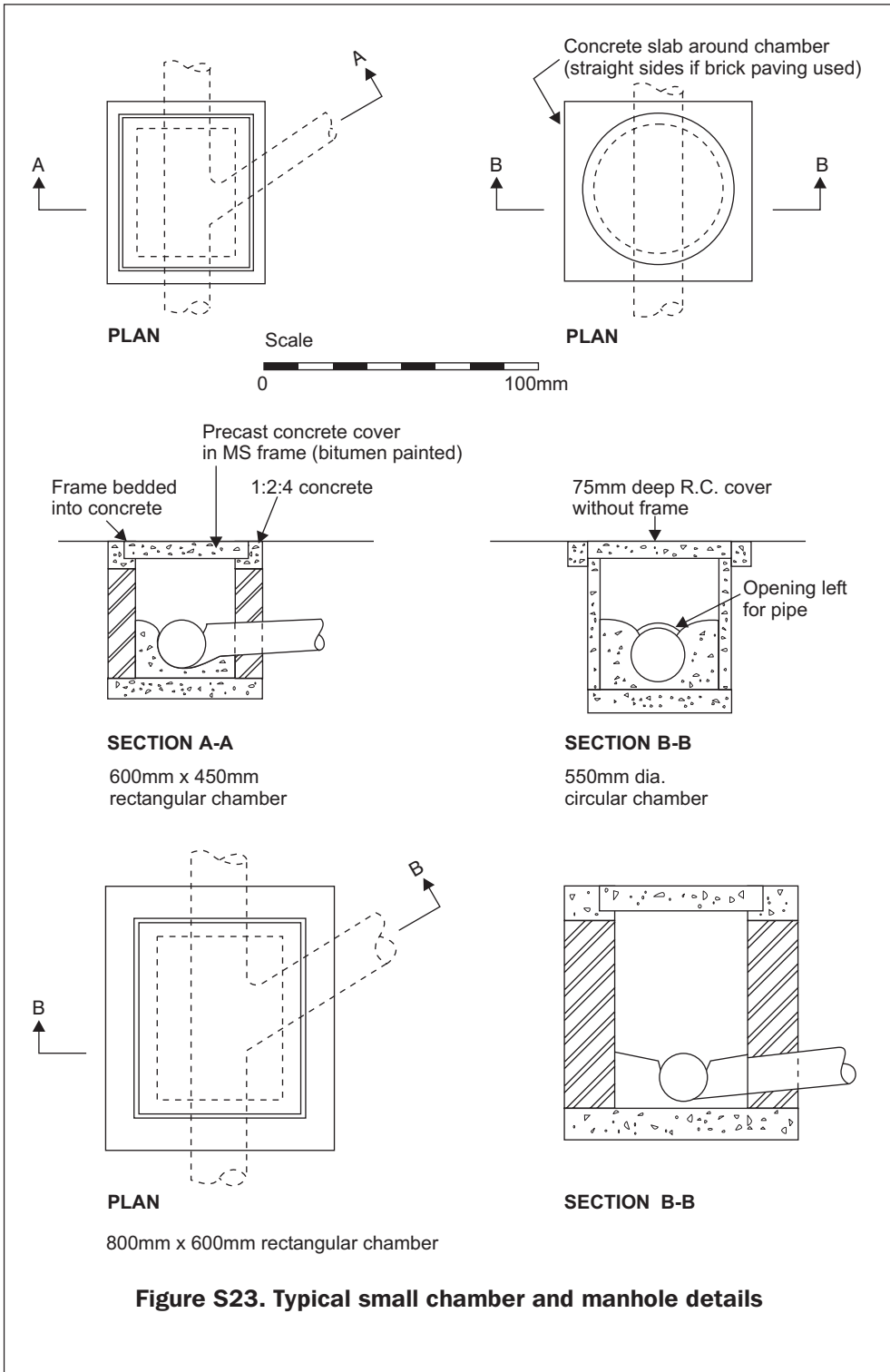

**Figure S23. Typical small chamber and manhole details**

**Table S5. Recommended minimum plan dimensions for manholes and chambers**

Depth to sewer invert (mm)	Entry required	Size of rectangular manhole/chamber (mm)	Diameter of circular chamber (mm)	Step irons required
<800	no	600 x 450	550	no
880-1000	partial	800 x 600	700	no
1000-1350	partial	1000 x 600	800	yes
1350-2000	yes	1200 x 750	1050	yes

There is an argument for reducing the number of manholes or even eliminating them since observation suggests that most blockages are caused by material which enters sewers through missing or broken manhole covers. Given existing codes and standards and the probability that some connections will not be adequately trapped, it is unlikely that this approach will be widely adopted for conventional systems.

A compromise approach, which would also be possible for conventional systems, would be to provide manholes with covers below ground level as shown in Figure S24. This would enable access to be gained in the event of problems but would prevent it under normal conditions. It would seem to be particularly applicable with surfacing materials such as bricks and blocks which can be removed and then reinstated. This approach should only be used on tertiary sewers.

### House connections

**Minimum pipe diameter.** This should be 100mm for concrete and clayware connections from WCs. 90mm uPVC pipes may be used for lengths up to 5m downstream of WCs. Underground connections carrying sullage only should normally be 75mm diameter but a reduction to 50mm may be appropriate for individual connections preceded by a grit/grease trap.

**Minimum gradient.** For connections from WCs this should be 1:50. A gradient of 1:100 will be acceptable for a connection carrying sullage water only, provided that it is preceded by a grit/grease trap.



***On-plot layout.*** Where possible, on-plot drains should all be directed to one point on the plot or immediately outside it in order to allow one connection from the plot to the sewer. A small inspection chamber should be built at this point and ideally the connection to the sewer should be trapped. It is advisable to have a grit/grease trap on the sullage drains above the point where they connect to the drain from the WC.

Where existing arrangements are such that all on-plot drains cannot be brought together into one sewer connection, no inspection chamber is necessary on connections less than about 5 metres in length, providing that they can be rodded back from a manhole at the junction with the sewer.

4c: SANITATION

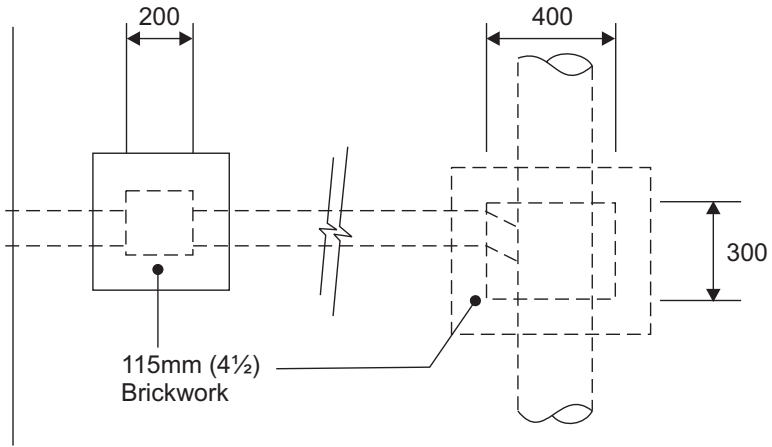

PLAN

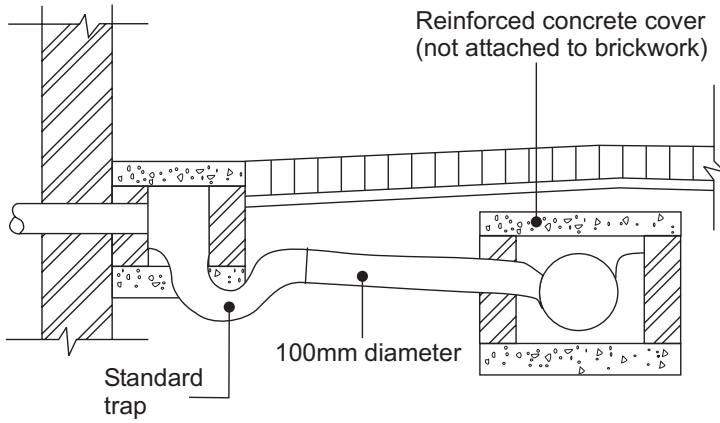

SECTION

Figure S24. Connection detail to buried manhole

---

## **Tool S6 Sanitation: Handy Tips**

---

### **On-plot pit latrines: where to use them**

- See Tool S1

### **On-plot pit latrines: construction tips**

- Construction requires both skilled and unskilled labour; construction of twin pit latrines requires specially trained masons.
- In very loose soils, settlement can cause breakage of sewer pipes in pour flush latrines.
- Pit walls should have sufficient openings (or holes/ honey comb) for liquid to infiltrate into soil.
- Locally available materials can be used for pit lining and the superstructure.
- With twin pit pour flush latrines, make sure that the pipes in and out of the junction chamber are properly aligned and levelled, otherwise the junction chamber blocks.

### **On-plot pit latrines: operation and maintenance tips**

- Do not use the latrine as a bathroom; the ground surrounding the pits rapidly becomes waterlogged unless the soil is very sandy and porous.
- Unblocking an offset pourflush latrine may require a plumber.
- Pit emptying can be carried out either manually or using suction equipment; municipal support is essential to locate a safe disposal site.
- No solid matter should be flushed which may cause blockages.
- Soap and detergents can be used for cleaning without affecting the digestion processes in the pit.
- Users have to be educated in the use and operation of twin pit latrines; a very common problem is that both pits are used simultaneously.

### Septic tanks: where to use them

- See Tool S1

### Septic tanks: construction tips

- Make sure that the tank is fitted with a vent pipe and an airtight cover.
- The walls need to be sufficiently thick to withstand lateral earth pressure and the base needs to resist uplift and cracking.
- Septic tanks need to be located so that there is adequate access for desludging equipment.

### Septic tanks: operation and maintenance tips

- Septic tanks should be desludged at regular intervals which depend upon the design capacity.
- Tank emptying is normally carried out using suction equipment; the practice of baling out the tank is messy and hazardous; municipal support is essential to locate a safe disposal site.
- No solid matter should be flushed which may cause blockages.
- Unblocking the pipework requires a plumber.
- Soap and detergents can be used for cleaning without affecting the digestion processes in the tank.

### Sewerage: where to use it

- See Tool S1

### Sewerage: construction tips

- Where ground conditions are poor, bed all pipes in sand or gravel.
- Socket and spigot pipes have flexible rubber ring joints which may be of poor quality: plain-ended pipes are suitable for tertiary sewers; the joints can be made by pushing jute-soaked cement slurry into the joint and casting 1:3 concrete around the joint.
- Use manholes at changes of direction and changes of pipe size.
- When the pipe size increases, match the pipe soffits, not the inverts.
- Use buried manholes wherever possible, but keep a clear record of their location.
- Excavation in areas of high water table pose serious problems and requires expensive dewatering.
- Accurate measurement of levels and falls is essential.
- Sewer laying is highly specialised and needs experienced contractors with close supervision.
- Certain soil types e.g. black cotton soils create serious problems; seasonal expansion and contraction of the ground causes movement of the sewers which can open up the joints, obstruct the flow and cause excessive leakage. Provision of a sand cushioning may help overcome the problem.
- Provide a concrete surround where there is significant top-loading e.g. shallow road crossings, or exposed above-ground sections.
- Pipes can be manufactured locally.

### Sewerage: operation and maintenance tips

- Make sure that 'as-built' drawings and records are kept including all manhole details.
- O&M demands detailed human and financial resource planning.
- Appropriate equipment needs to be procured for unblocking and cleaning sewers; this is expensive.
- There are opportunities for letting maintenance contracts.
- High level engineering support is essential for O&M.
- Regular maintenance of electrical and mechanical equipment is essential.
- Awareness raising amongst users is essential: for example, not to dispose of bulky solid items; use traps on all sullage connections.
- Cannot be managed by communities.
- High operating costs where pumping is required.
- Check manhole covers regularly and replace all broken or missing covers.

